

# VIII. Weak Interactions: W and Z bosons

❖ The force carriers in weak interactions are (as in QED and QCD) spin-1 **bosons** that **couple** to **quarks** and **leptons**.

→ The force carriers of weak interactions are three **intermediate vector bosons**:  $W^+$  and  $W^-$  (mass 80.4 GeV) and  $Z^0$  (91.2 GeV). Since the  $W^+$ ,  $W^-$  and  $Z^0$  bosons are **very massive** particles, the weak interactions have a very **short range** (order of  $2 \times 10^{-3}$  fm).

❖ Before the Electroweak Theory was developed, all observed weak processes were **charged current reactions** (e.g.  $\beta$ -decay) mediated by  $W^+$  or  $W^-$  bosons.

→ The Electroweak theory predicted that **neutral current reactions** caused by the  $Z^0$  boson should exist.

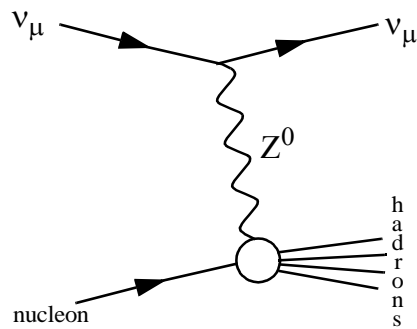

Figure 78: A predicted neutral current reaction which is characterized by no muon in the final state

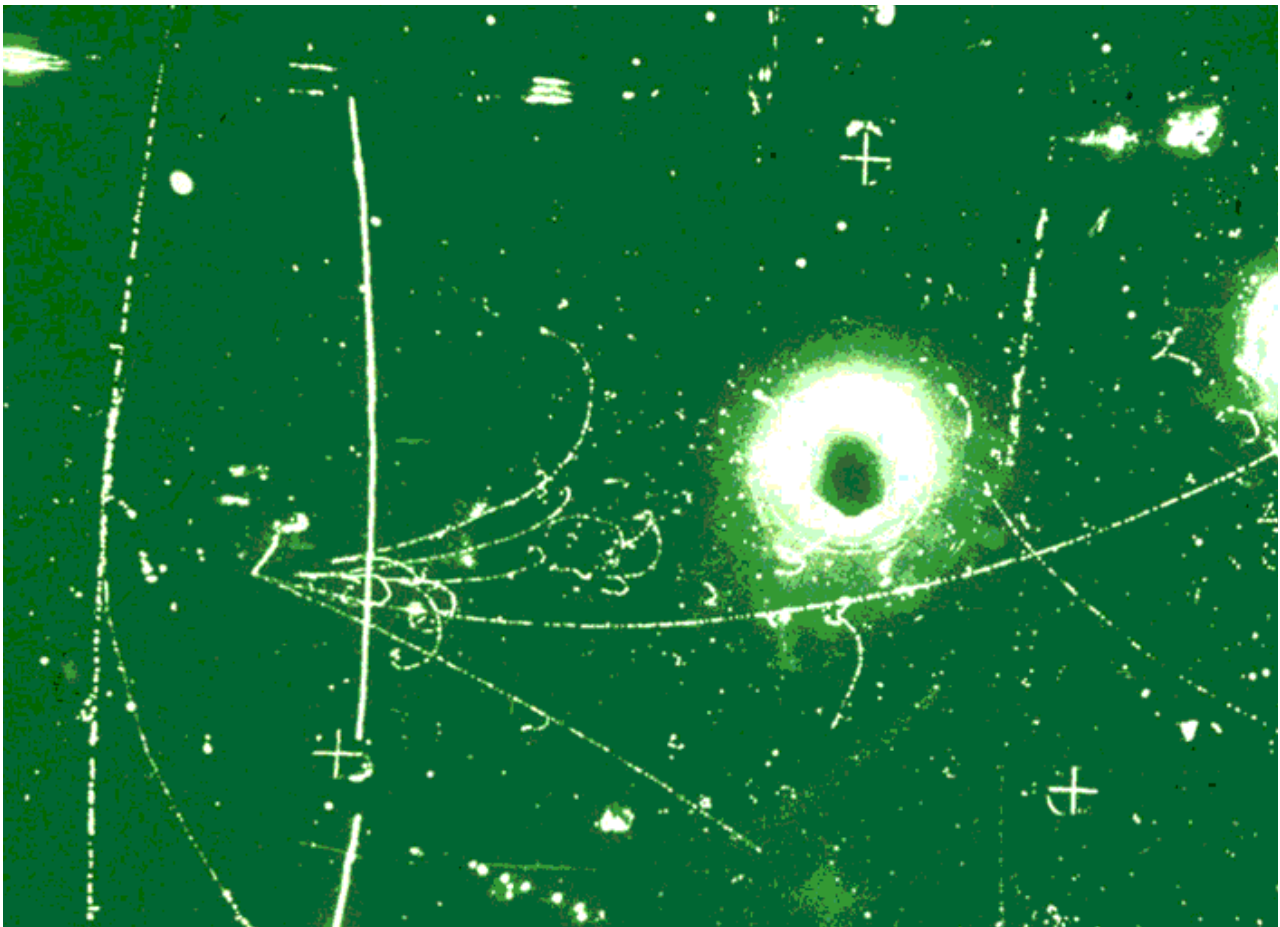

Figure 79: One of the first neutral current reactions as seen by the Gargamelle bubble chamber experiment in 1973.

## Discovery of the $W$ and $Z$ bosons.

❖ The first study of direct production and decay of the  $W$  and  $Z$  vector bosons were made by the  $UA1$  and  $UA2$  experiments at the SPS proton-antiproton collider at CERN.

→ **PRODUCTION:** In proton colliders the  $W$  and  $Z$  bosons are produced by quark-antiquark annihilations:

$$u + \bar{d} \rightarrow W^+ , \quad d + \bar{u} \rightarrow W^- \quad (94)$$

$$u + \bar{u} \rightarrow Z^0 , \quad d + \bar{d} \rightarrow Z^0 \quad (95)$$

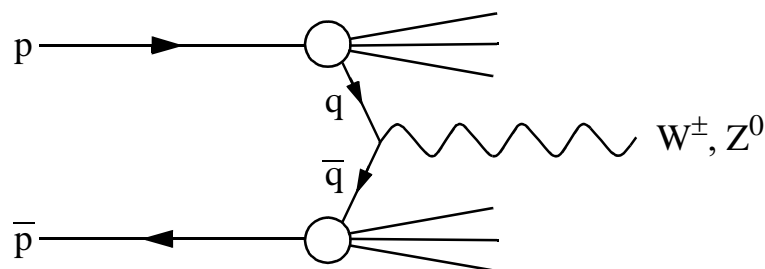
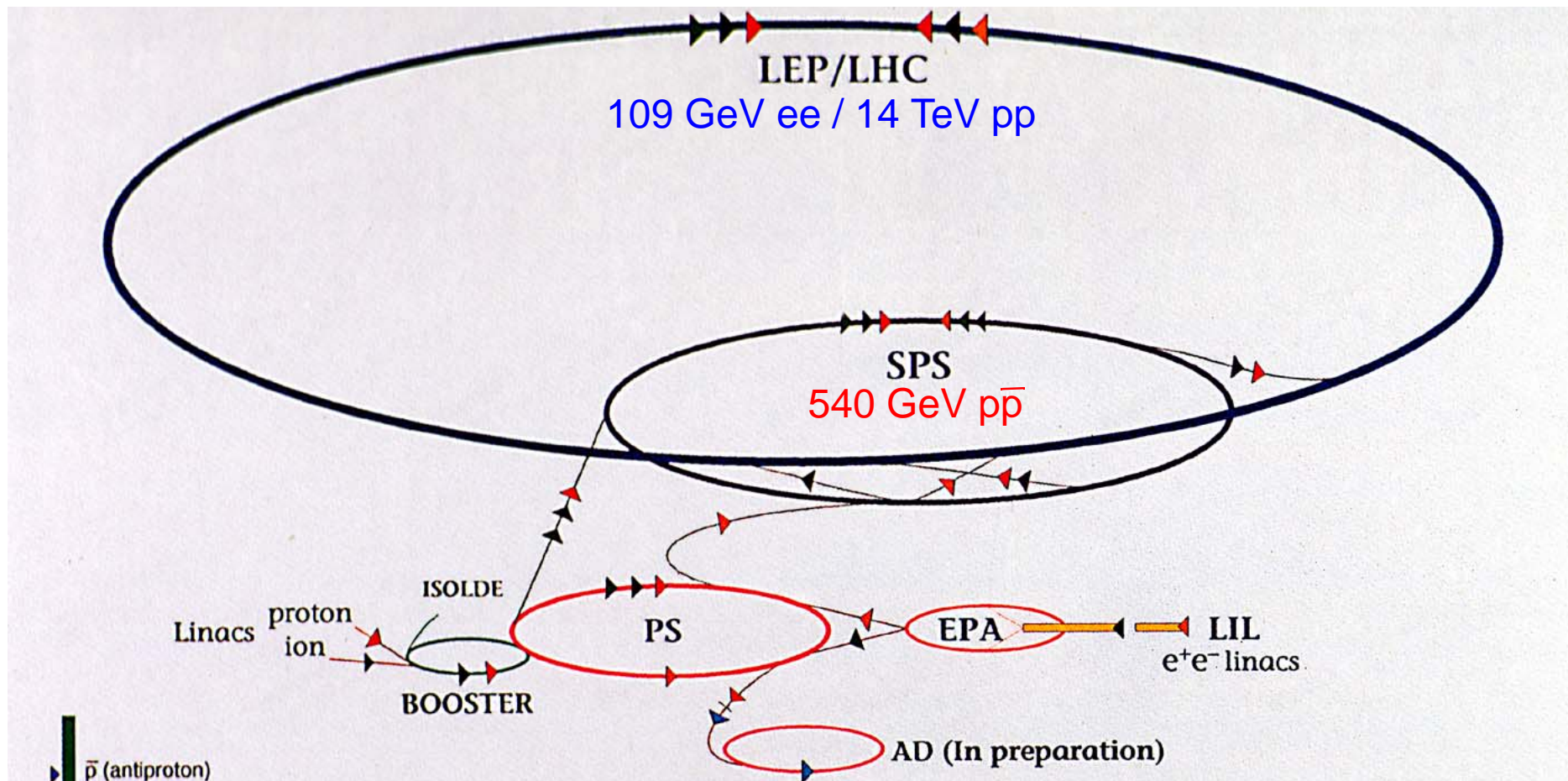

Figure 80: The mechanism of  $W^\pm$  and  $Z$  production in  $p\bar{p}$  annihilation.





In hadron colliders, the **energy of the quarks** and gluons that participate in the interaction is only a **fraction of the energy** of the colliding **protons**. To produce W- and Z-bosons with a mass of 80-90 GeV it was therefore needed to build an accelerator where the protons had an energy of 270 GeV.



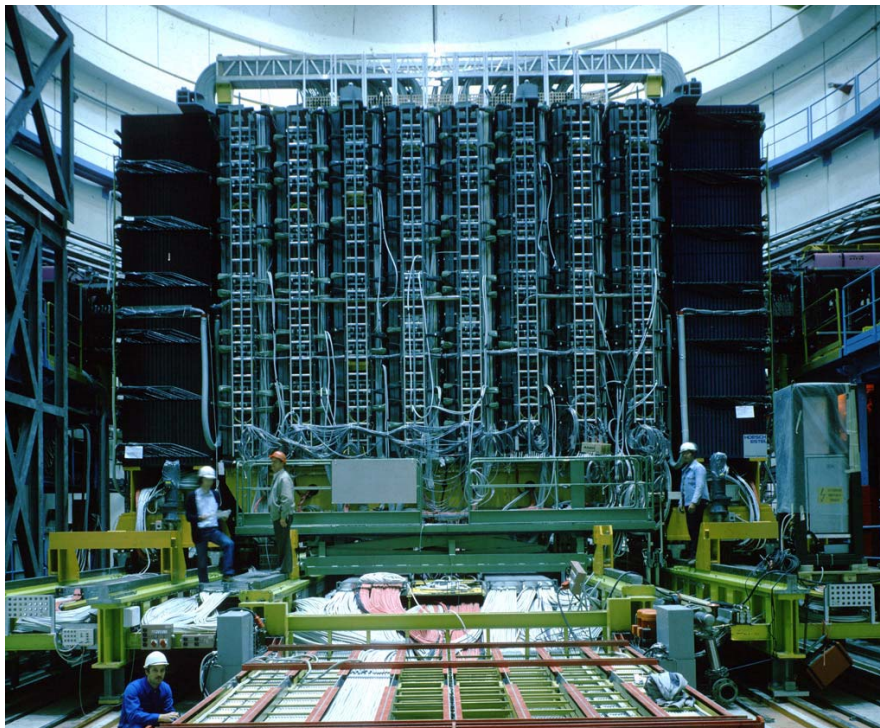
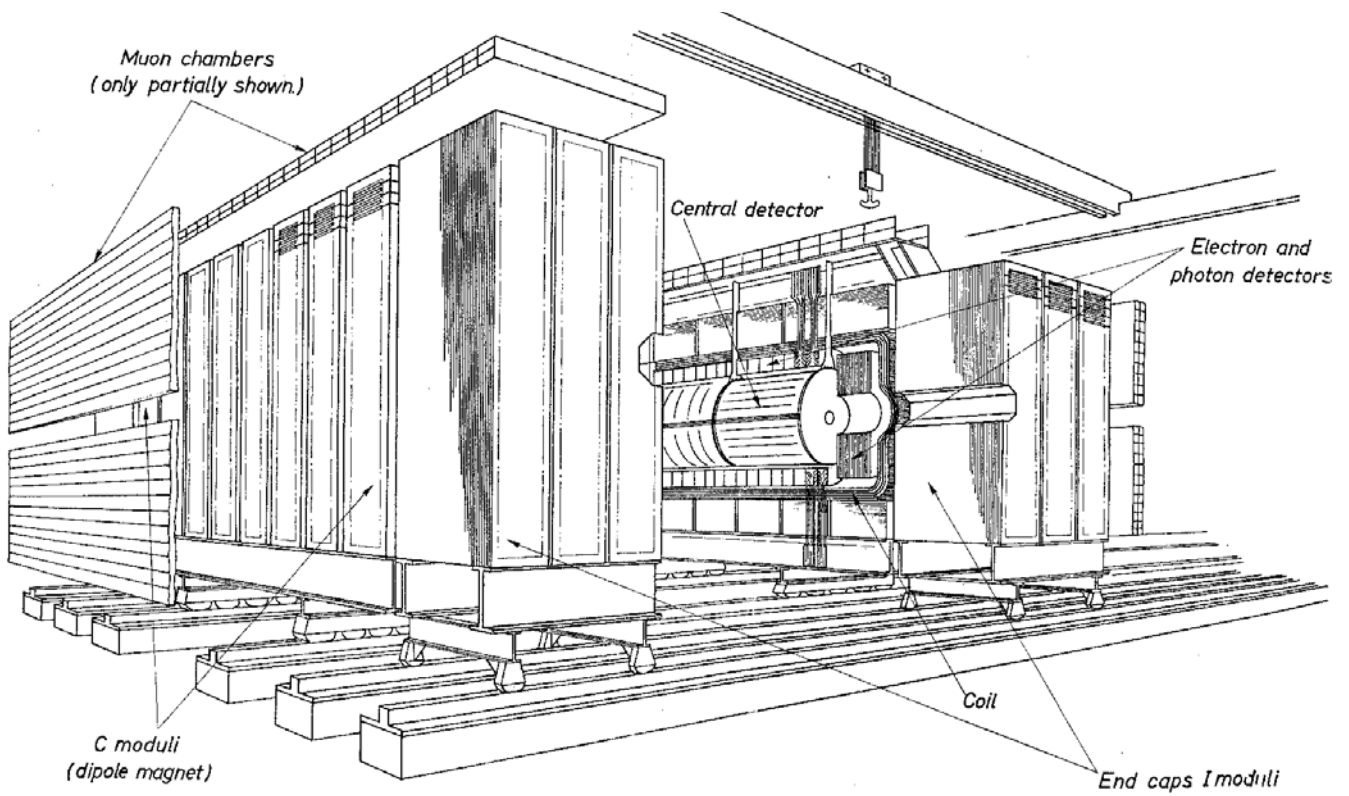

Figure 81: The UA1 experiment where the  $W$  and  $Z$  bosons were discovered.

## DISCOVERY OF THE W BOSON

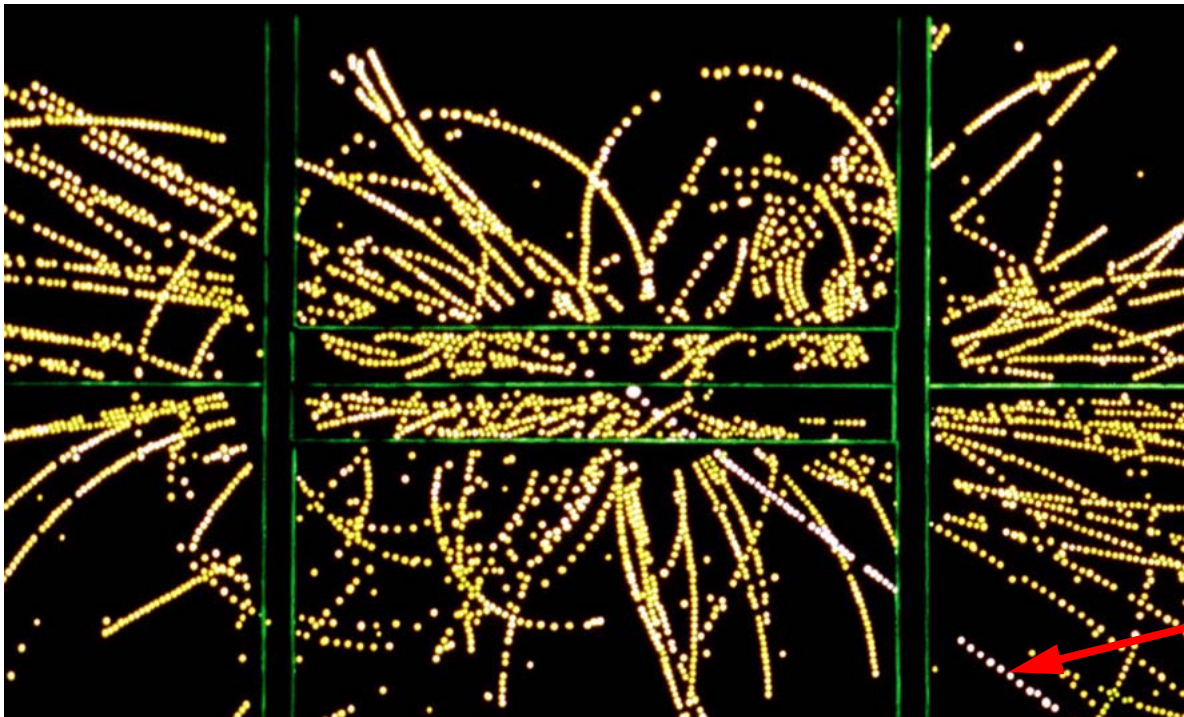

Figure 82: A W event observed by the UA1 detector in 1982. A high transverse momentum electron is indicated by the arrow.

The signature of a W boson is:

- a lepton with **large momentum** ( $>10 \text{ GeV}/c$ ) emitted at a wide angle to the beam ( $>5^\circ$ ).
- large “**missing transverse momentum**” carried away by the neutrino.

$$\text{Transverse Energy: } E_T = E \sin \theta$$

$$\text{Tranverse Momentum: } P_T = P \sin \theta$$

where  $\theta$  is the angle to the colliding beams.

- $E_T = P_T$  if the mass of a particle is small compared to its energy.
- If the **momentum of all particles** in a collision is added up the result should be **zero** (momentum conservation). Neutrinos can, however, not be detected and if the total momentum is different from zero the event is said to have **missing momentum** (or missing energy).

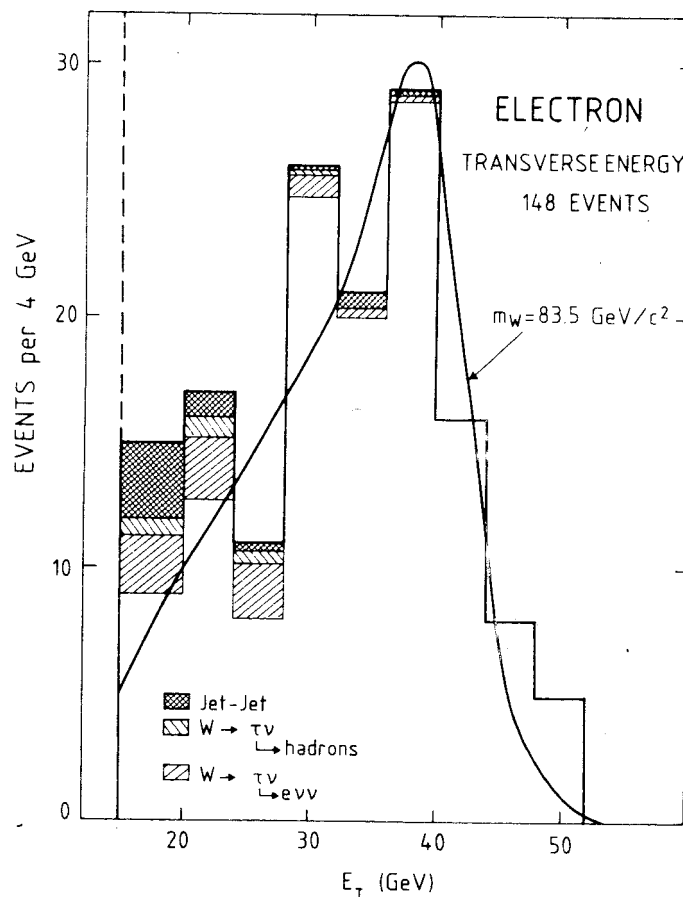

Figure 83: The UA1 transverse energy distribution of electrons in events with more than 15 GeV missing energy.



→ From the first 148 electron and 47 muon events recorded by the **UA1** it was estimated that

$$M_W = 83,5 \pm 2,8 \text{ GeV} \quad \Gamma_W \leq 6,5 \text{ GeV}$$

→  $W$  bosons can be pair-produced in  $e^+e^-$  annihilation. From measurement at the **LEP** accelerator, the  $W$  mass and width is now estimated to be

$$M_W = 80,43 \pm 0,05 \text{ GeV} \quad \Gamma_W = 2,1 \pm 0,1 \text{ GeV}$$

→ The **branching ratios** of the leptonic decay modes of the  $W^\pm$  have been measured to be about **11%** for each lepton generation.

# STUDIES OF THE W AT LEP.

❖ The DELPHI experiment was one of the four experiments at LEP which studied W-production in e+e- collisions.

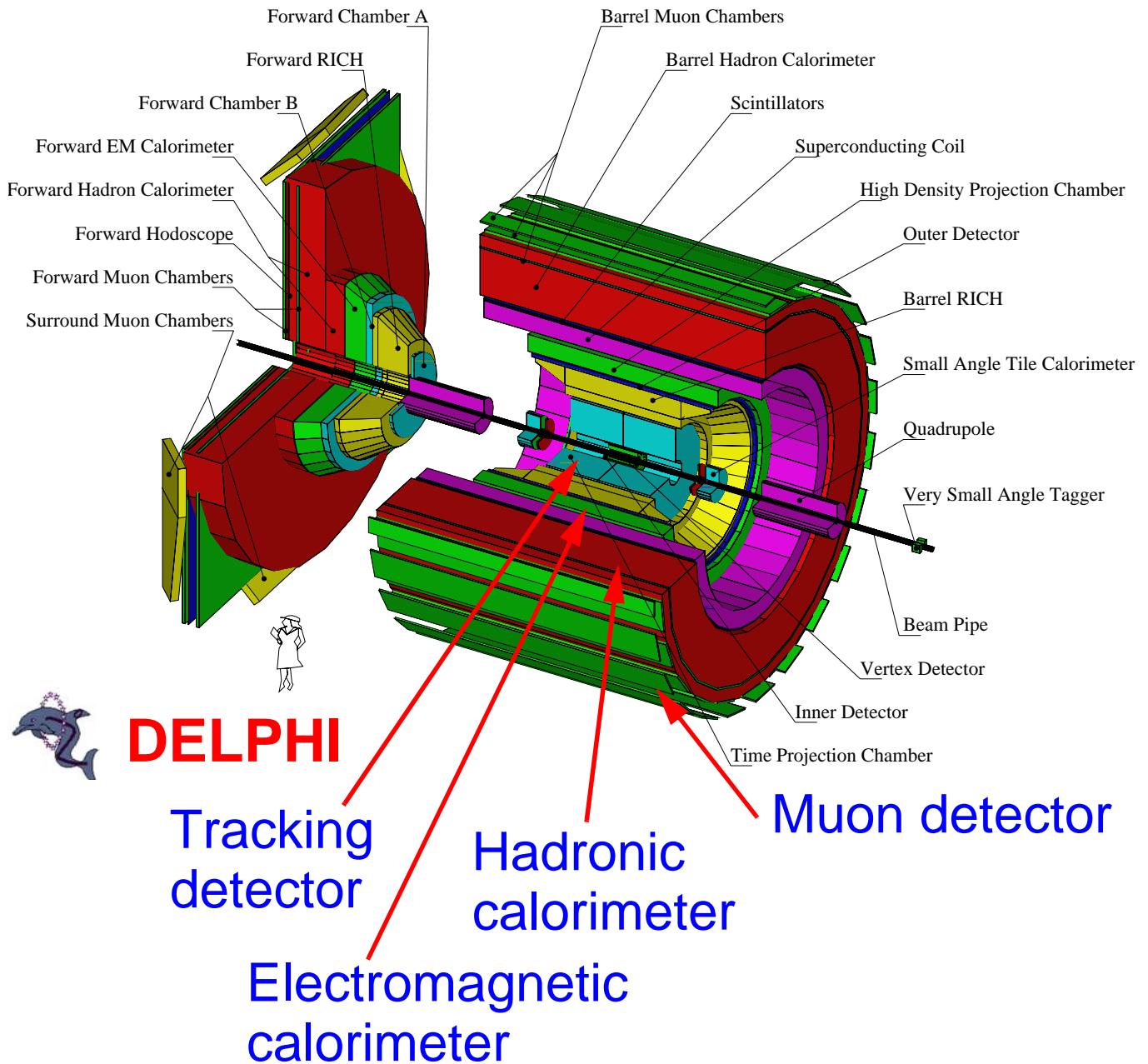

Figure 84: The DELPHI experiment at LEP.



The W bosons were produced in pairs at

LEP:

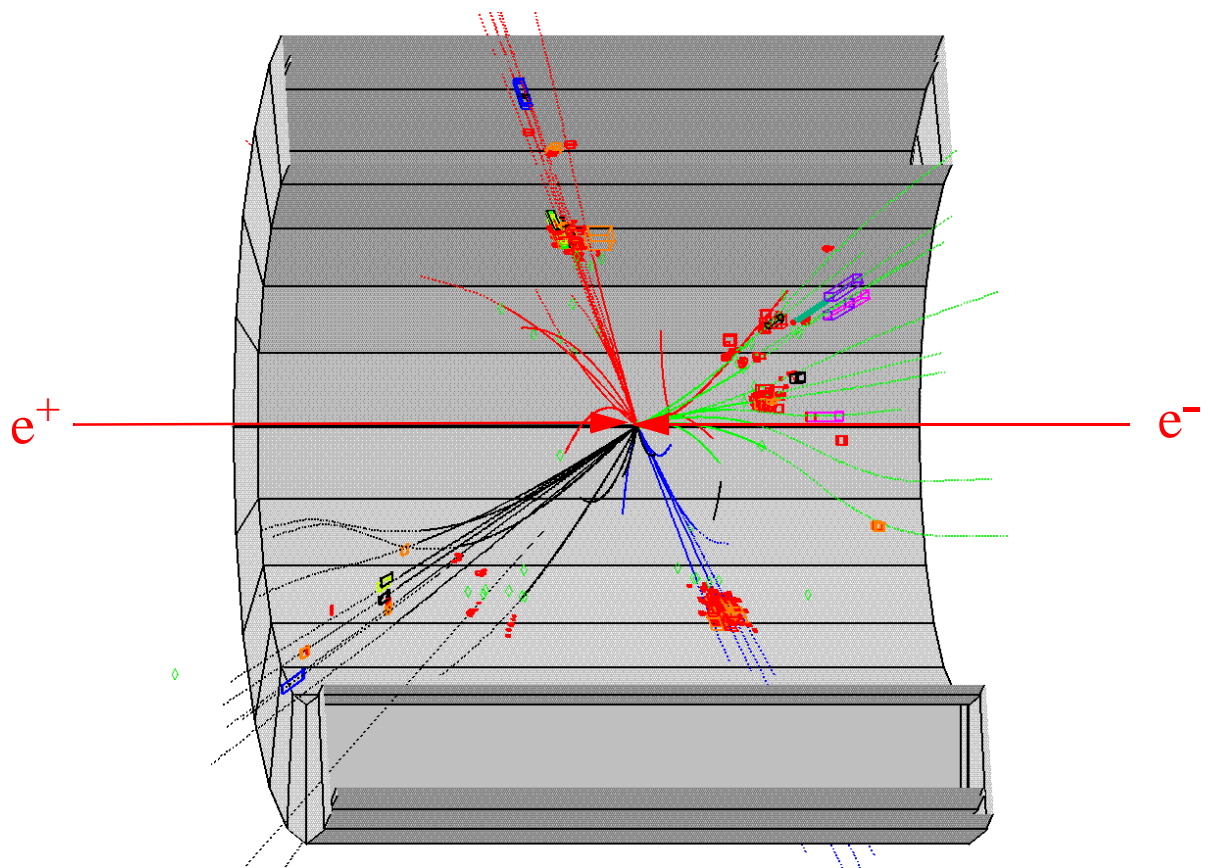
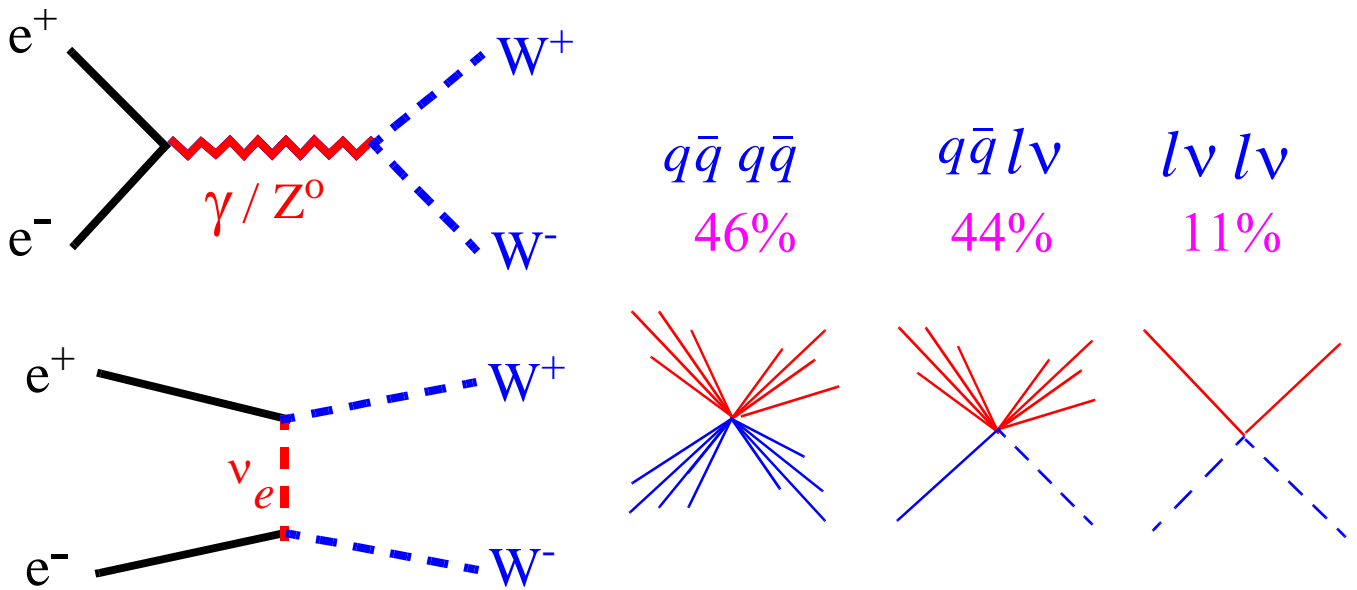

Figure 85: A WW-event with 4 jets in the DELPHI experiment.



The mass of the W can be calculated from the energy and the direction of the jets:

$q\bar{q} q\bar{q}$   
46%

$$M_W^2 = (\vec{P}_q + \vec{P}_{\bar{q}})^2 \quad (\text{4-vectors})$$

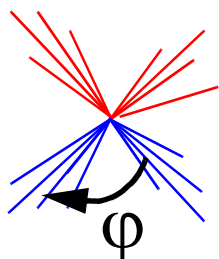

$$M_W^2 = 2 E_q E_{\bar{q}} (1 - \cos \varphi)$$

if  $m_q = 0$

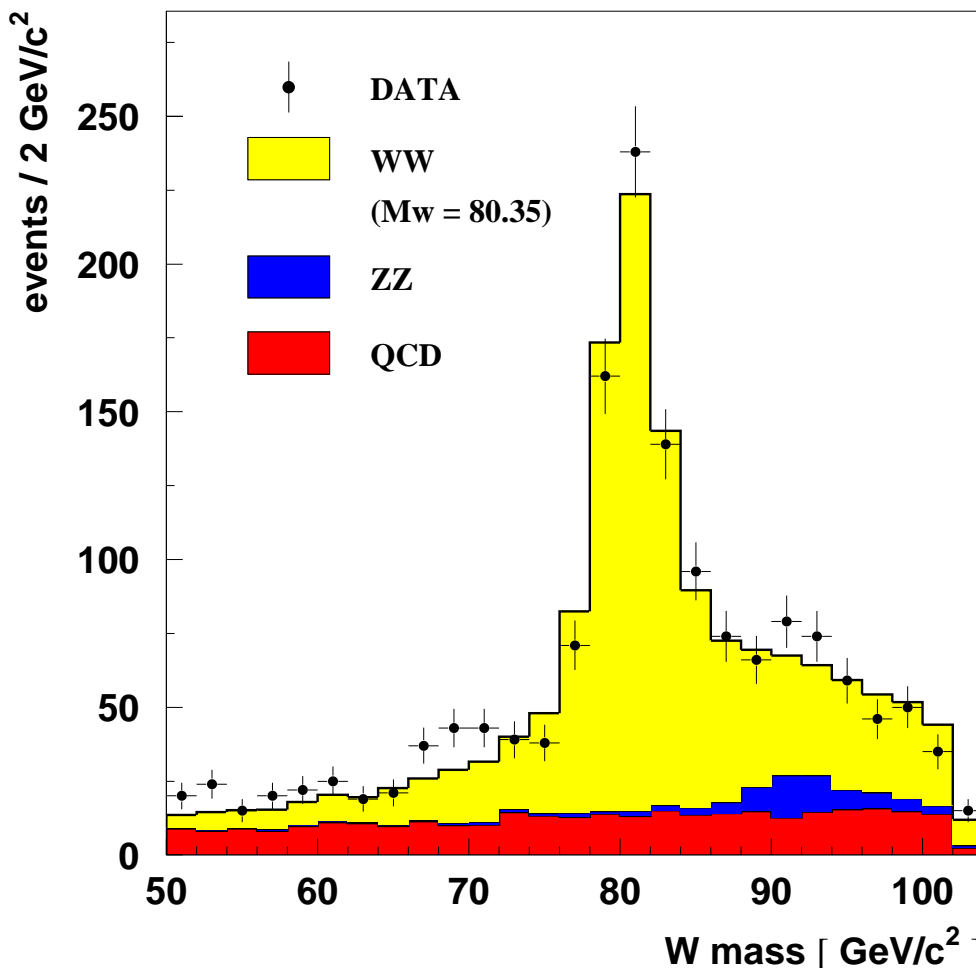

Figure 86: The mass distribution from jet-pairs in WW events selected by the DELPHI experiment.



## DISCOVERY OF THE Z BOSON

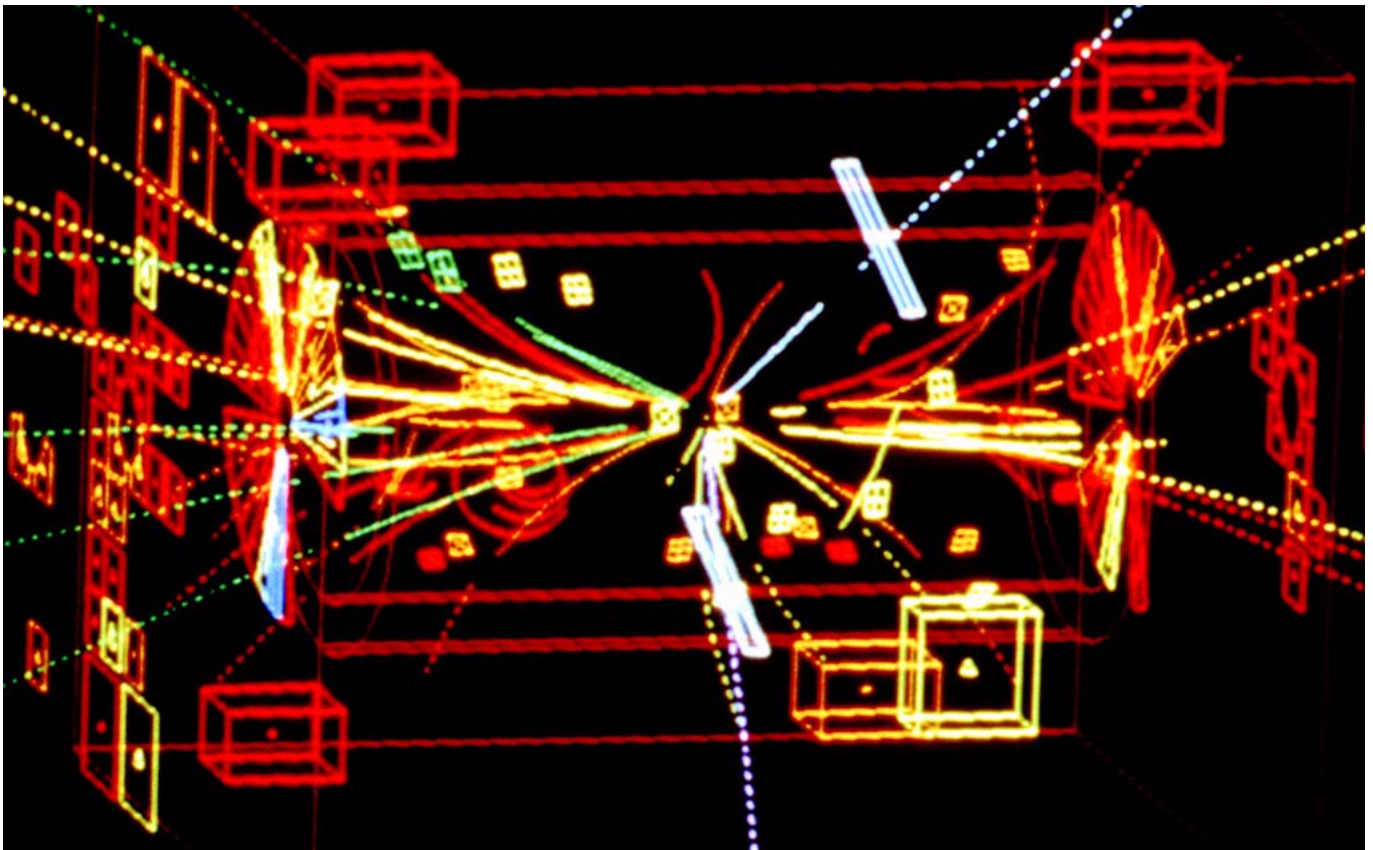
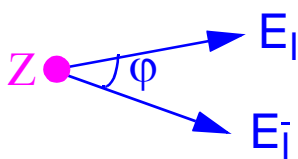

Figure 87: The production of a  $Z^0$  event in the UA1 detector.

- The signature of a  $Z^0$  boson created in  $p\bar{p}$  collision is a **pair of leptons** with large transverse momenta.
- The mass of the  $Z^0$  is given by the invariant **mass of the leptons**:



$$M_Z^2 = \overset{\text{if } m_l=0}{=} 2 E_l E_{\bar{l}} (1 - \cos \varphi)$$

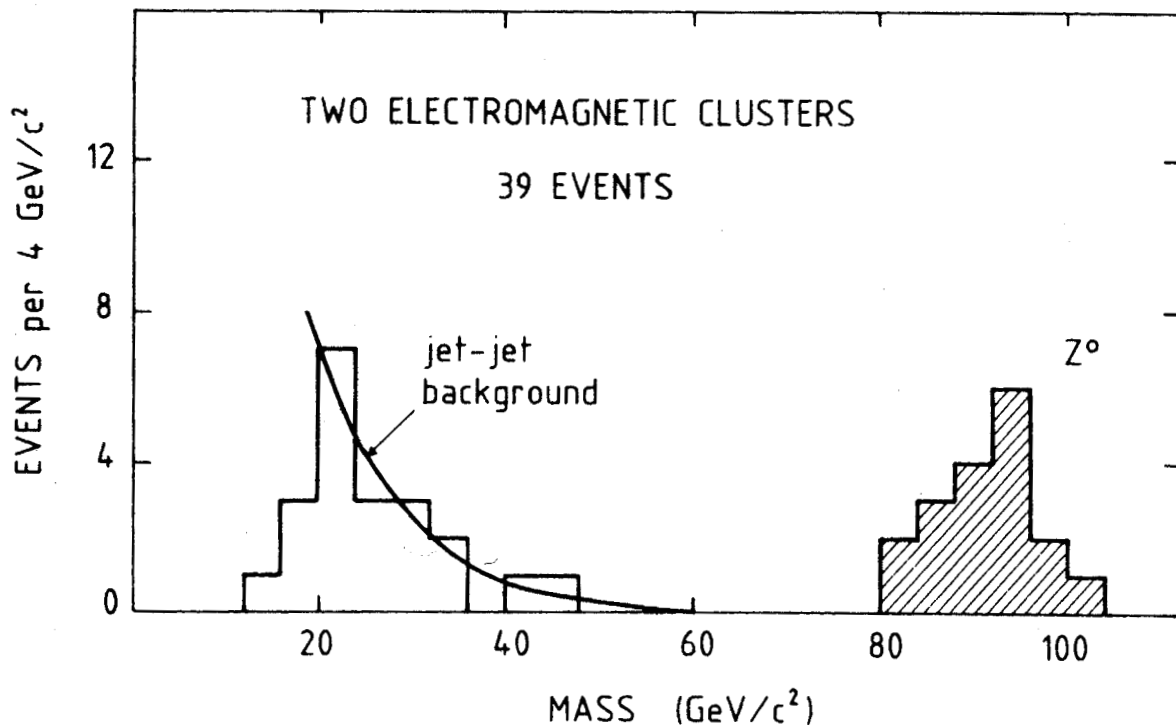

Figure 88: The UA1 mass distribution of pairs of electrons where each electron has  $E_T > 8$  GeV.

→ From the first 18 electron and 10 muon events recorded by the **UA1** it was estimated that

$$M_Z = 93,0 \pm 1,4 \text{ GeV} \quad \Gamma_Z \leq 8,1 \text{ GeV}$$

→ From measurement at the **LEP** accelerator, the Z mass and width is now estimated to be

$$M_Z = 91,188 \pm 0,002 \text{ GeV} \quad \Gamma_Z = 2,495 \pm 0,002 \text{ GeV}$$

The **branching ratios** of the leptonic decay modes of the Z are measured to be about **3%** for each lepton.

# STUDIES OF THE Z AT LEP.

Example of events in which Z bosons are produced:

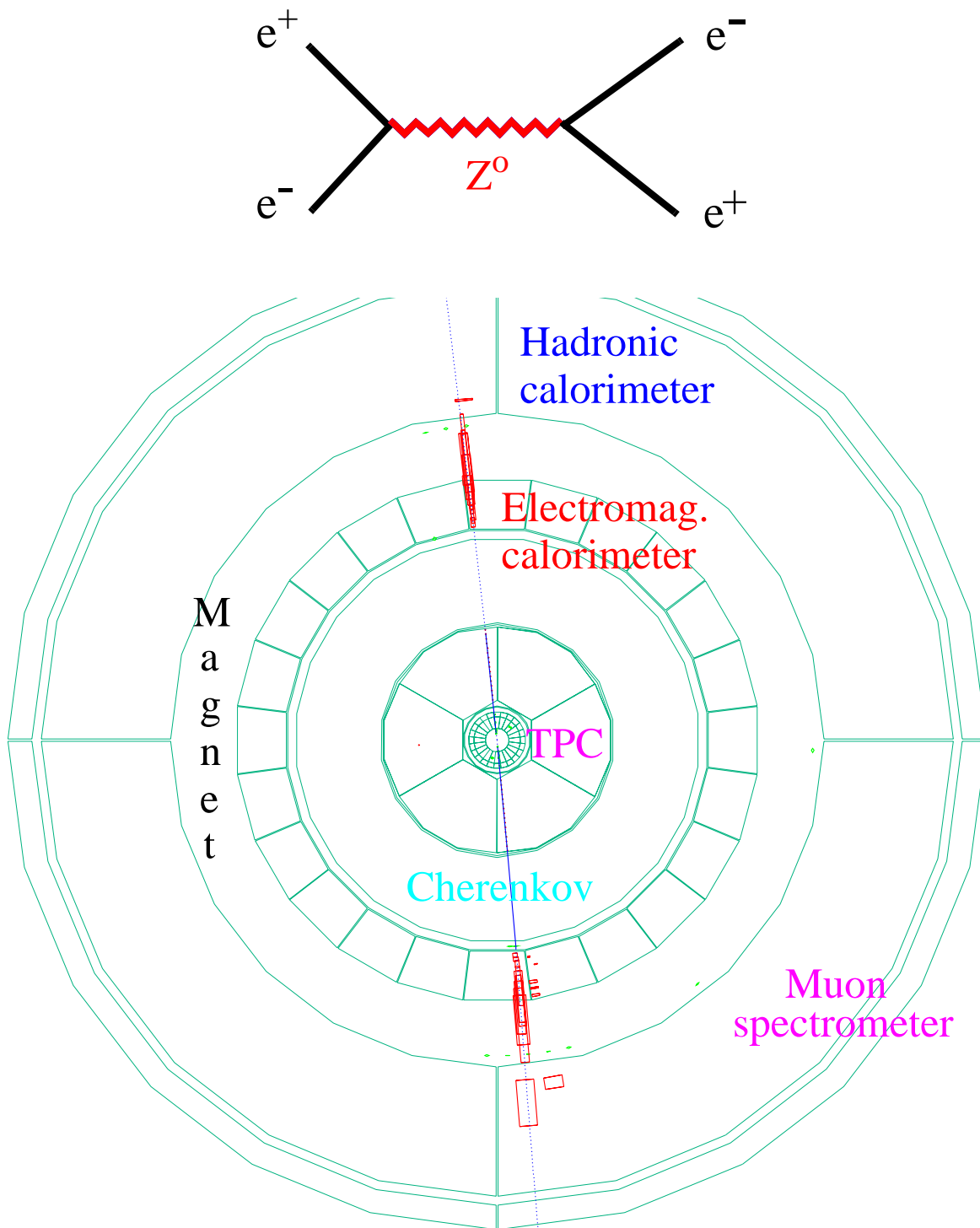

Figure 89: A Z boson decays to an electron pair in DELPHI.

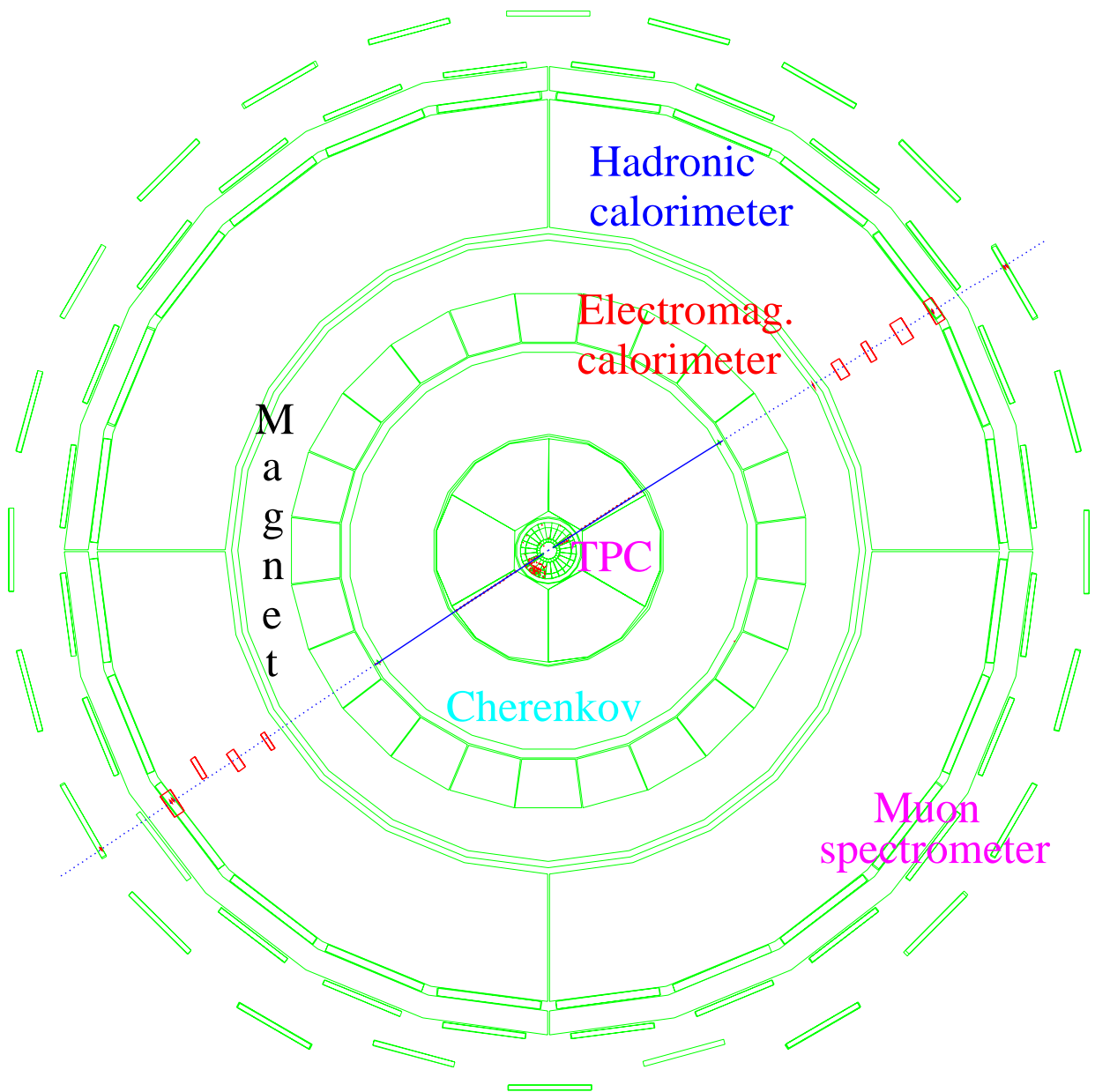
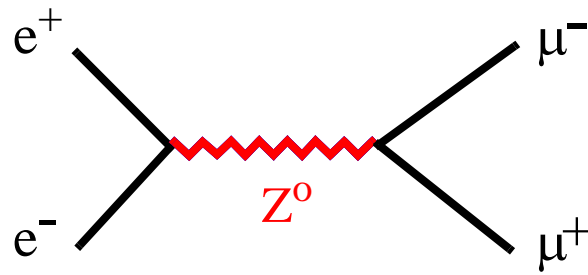

Figure 90: A Z boson decays to a muon pair in DELPHI.



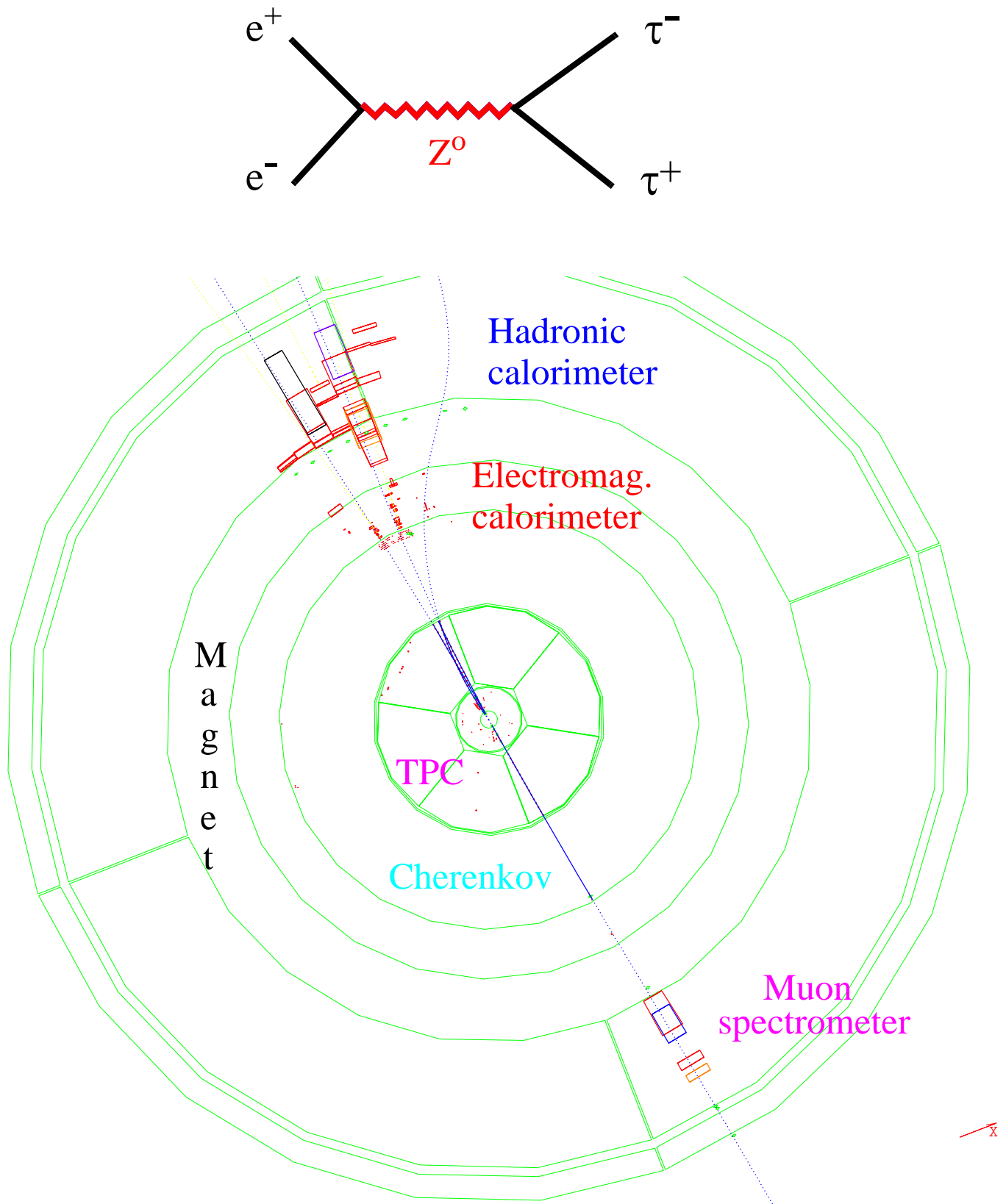
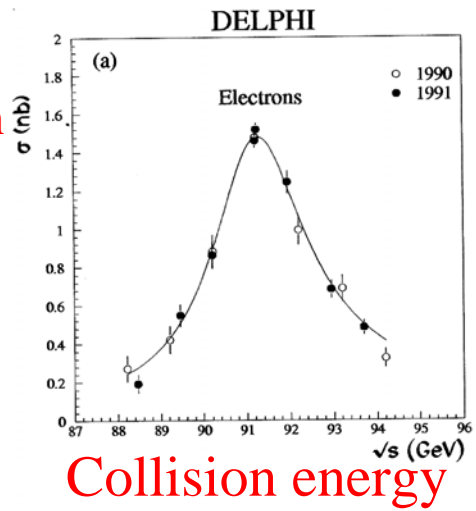
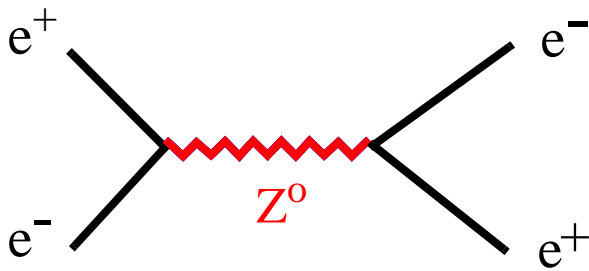

Figure 91: A Z boson decays to a tau pair in DELPHI.

Cross-section



Collision energy

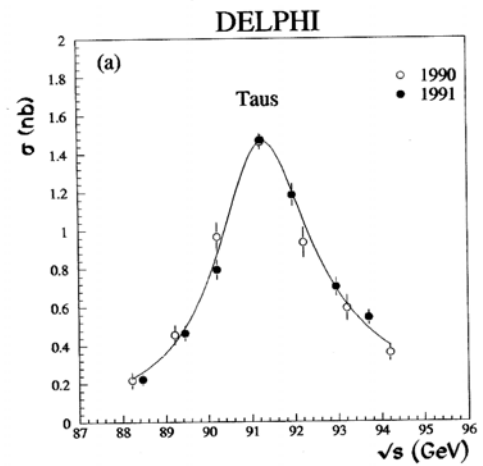
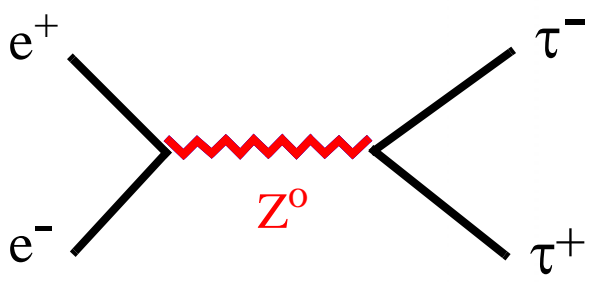
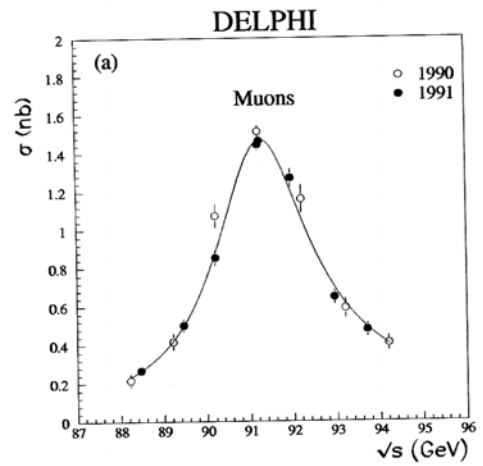
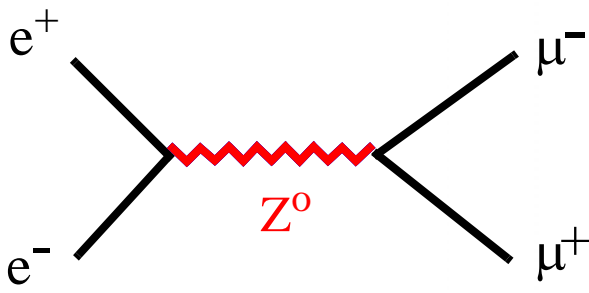
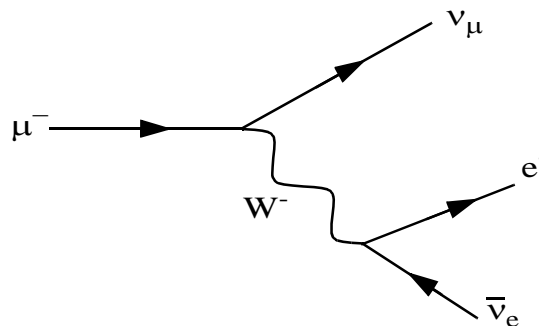

Figure 92: A cross section measurement of the leptonic decay of the  $Z^0$ .

## Charged current reactions

❖ **Charged current** reactions are reactions mediated by the charged **W**-bosons. They can be divided up into:

1) purely *leptonic* processes:  $\mu^- \rightarrow e^- + \bar{\nu}_e + \nu_\mu$



2) purely *hadronic* processes:  $\Lambda \rightarrow \pi^- + p$

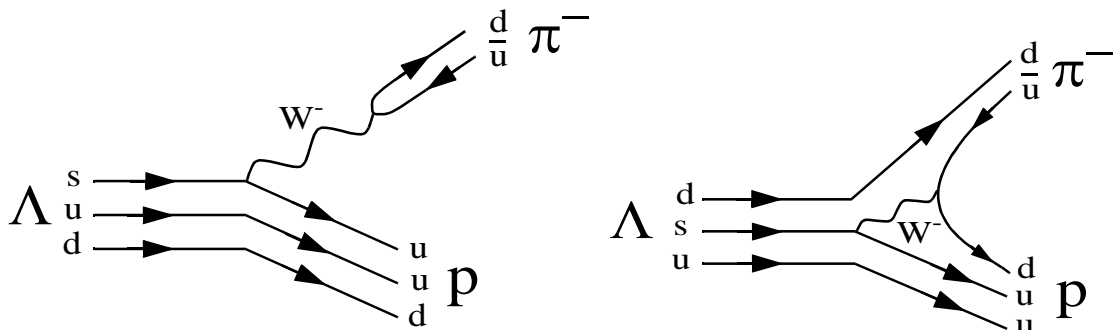

3) *semileptonic* reactions:  $n \rightarrow p + e^- + \bar{\nu}_e$

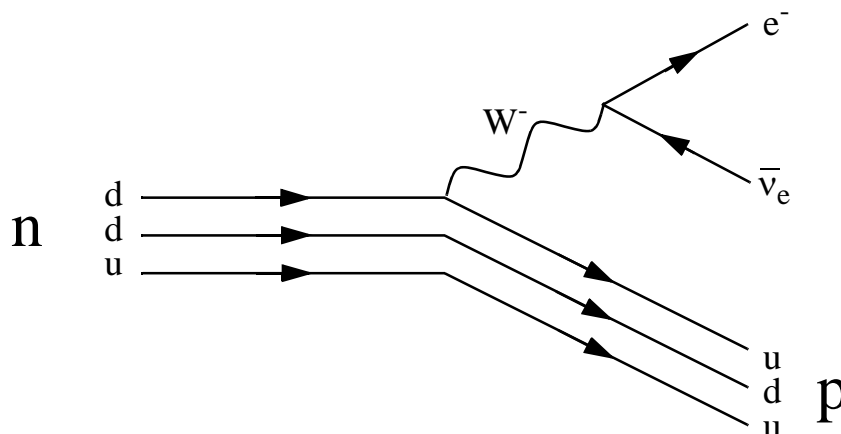

**Reminder:** All the electromagnetic interactions can be built from eight basic interactions:

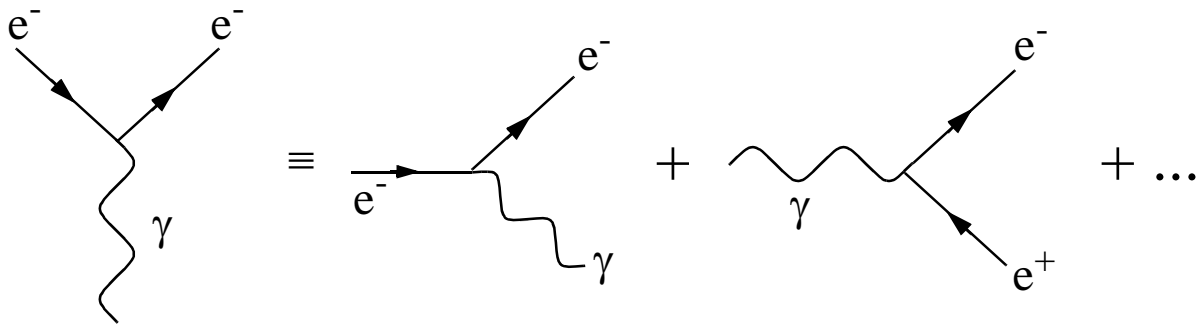

Figure 93: The basic vertex for electron-photon interactions.

❖ In a similar way, **leptonic weak interaction** processes can be built from a certain number of reactions corresponding to **basic vertices**:

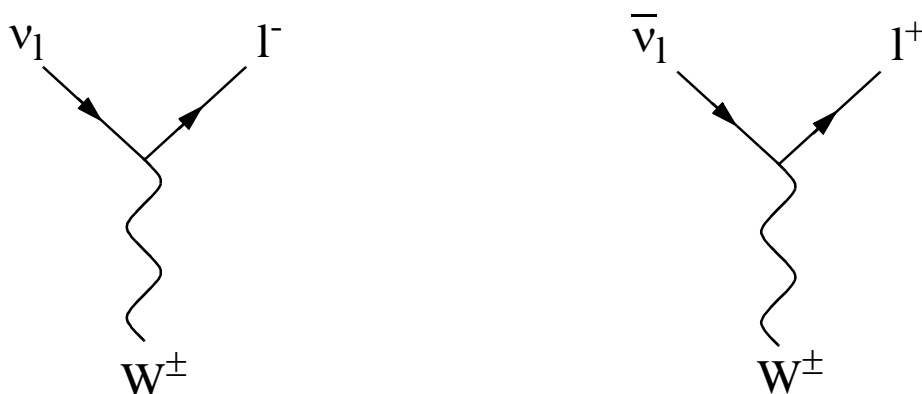

Figure 94: The two basic vertices for  $W^\pm$ -lepton interactions.



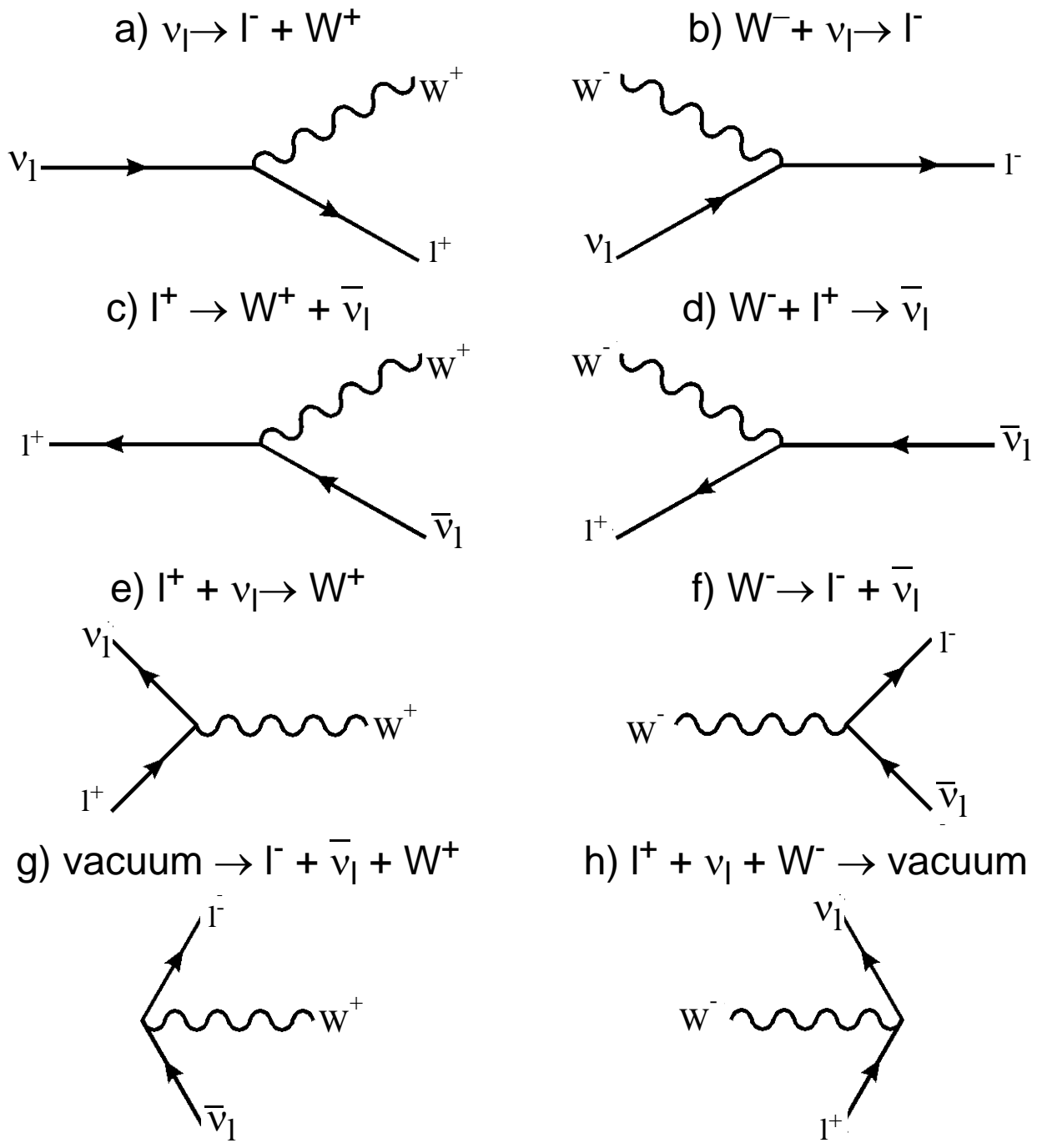

Figure 95: Eight basic reactions derived from the two basic W vertices. None of these processes, with the exception of e) and f) can occur by themselves since they do not conserve momentum and energy. e) and f) can occur by themselves if  $M_W > M_l + M_{\nu_l}$  ( $l = e, \mu, \tau$ ) in the W restframe.

❖ Weak interactions always **conserve the lepton numbers:  $L_e, L_\mu, L_\tau$** .

Diagram-wise this conservation is guaranteed by:

- at each vertex, there is one arrow pointing in and one pointing out.
- lepton indices “ $l$ ” are the same on both lines.

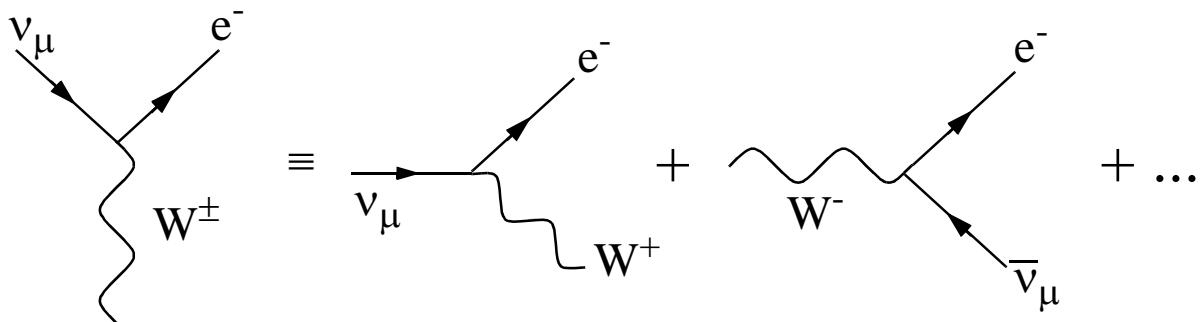

Figure 96: Vertices **violating** lepton number conservation.

❖ Leptonic vertices are characterized by the corresponding weak strength parameter  $\alpha_W$  which do not depend on the lepton type involved.

→ The decay rate of  $W \rightarrow e\nu$ , can be estimated to the first order to be

$$\Gamma(W \rightarrow e\nu) \approx \alpha_W M_W \approx 80\alpha_W \text{ GeV}$$

since the process involves only one vertex and lepton masses are negligible.

→ A measurement of the decay rate gives

$$\Gamma(W \rightarrow e\nu) \approx 0,2 \text{ GeV}$$

which translates into a value of the weak strength parameter  $\alpha_W$  of

$$\alpha_W \approx 0,003 \quad (96)$$

hence the strength of the weak interaction is comparable with that of the electromagnetic interaction for which  $\alpha_{em} \approx 0,007$  .

❖ Since  $\alpha_W$  and  $\alpha_{em}$  is of a similar size, why is the weak interaction weak ?

Compare the decay of charged and neutral pions:

### Electromagnetic decay

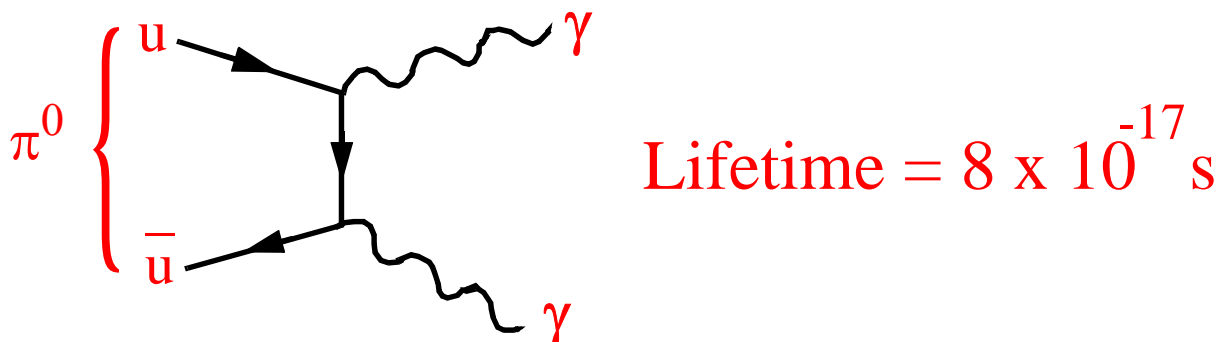

### Weak decay

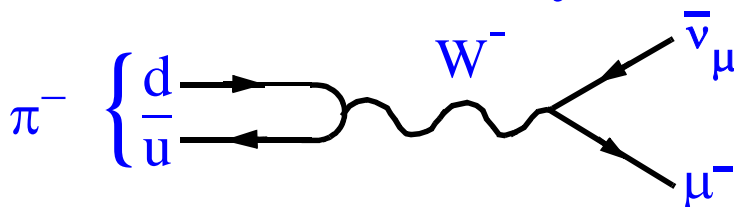

Lifetime =  $3000000000 \times 10^{-17}$  s

(Lifetime of a real W =  $0.00000003 \times 10^{-17}$  s)

➔ The apparent weakness of the weak interaction is due to the the very large W and Z masses !

❖ An analogue of electron-electron scattering by photon exchange is the inverse muon decay:

$$\nu_\mu + e^- \rightarrow \mu^- + \nu_e$$

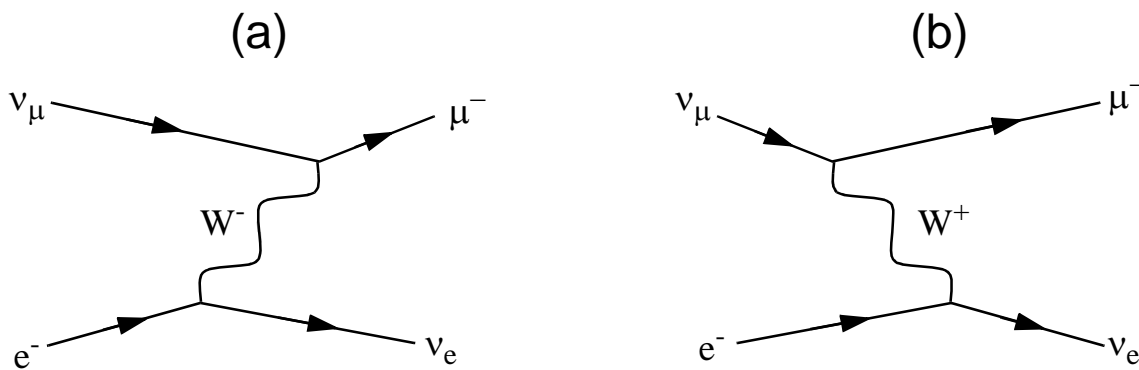
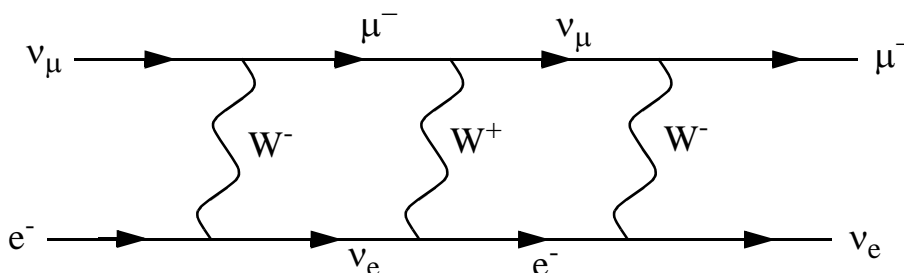

Figure 97: Time-ordered diagrams for inverse muon decay.

Time ordering implies changing the sign of the current !

➔ The above diagrams are of second order while the following diagram is of the **sixth order**



This diagram gives a **contribution of order  $\alpha_W^6$**  to the total cross section while the second order diagram contributes  $\alpha_W^2$ .

❖ Since W bosons are very heavy, inverse muon decay can be approximated by a **zero-range interaction**:

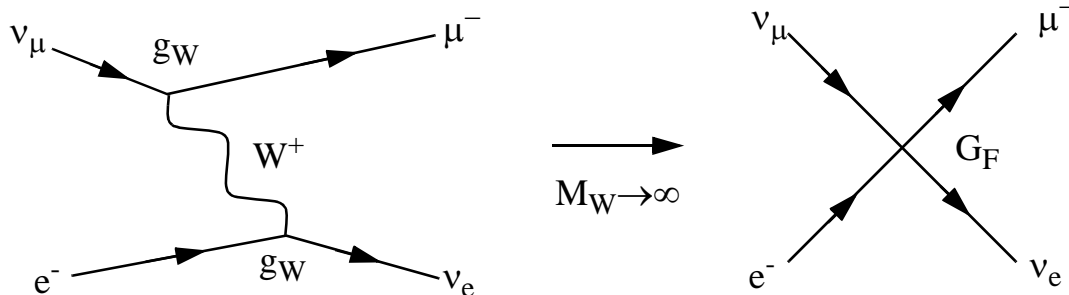

Figure 98: A low-energy zero-range interaction in muon decay.

- ➔ The strength of the zero-range interaction is given by the **Fermi coupling constant  $G_F$** .
- ➔ Taking into account spin effects, the relation between  $\alpha_W$  and  $G_F$  in the zero-range

approximation is:

$$\frac{G_F}{\sqrt{2}} = \frac{g_W^2}{M_W^2} = \frac{4\pi\alpha_W}{M_W^2}$$

where  $g_W$  is a **coupling constant** which characterizes the strength at the charge current vertex:

$$\alpha_W \equiv g_W^2/4\pi = 0,004 \text{ to be compared with } \alpha = 0,007 .$$