

# X. Charge conjugation and parity in weak interactions

## REMINDER:

### *Parity*

❖ The parity transformation is the transformation by reflection:

$$\rightarrow \vec{x}_i \rightarrow \vec{x}'_i = -\vec{x}_i$$

A parity operator  $\hat{P}$  is defined as

$$\rightarrow \hat{P}\psi(\vec{x}, t) = p\psi(-\vec{x}, t) \quad \text{where } p = \pm 1$$

### *Charge conjugation*

❖ The charge conjugation replaces particles by their antiparticles, reversing charges and magnetic moments

$$\rightarrow \hat{C}\Psi_a = c\Psi_{\bar{a}} \quad \text{where } c = \pm 1$$

meaning that from the particle in the initial state we go to the antiparticle in the final state.

# Reminder

# Symmetries

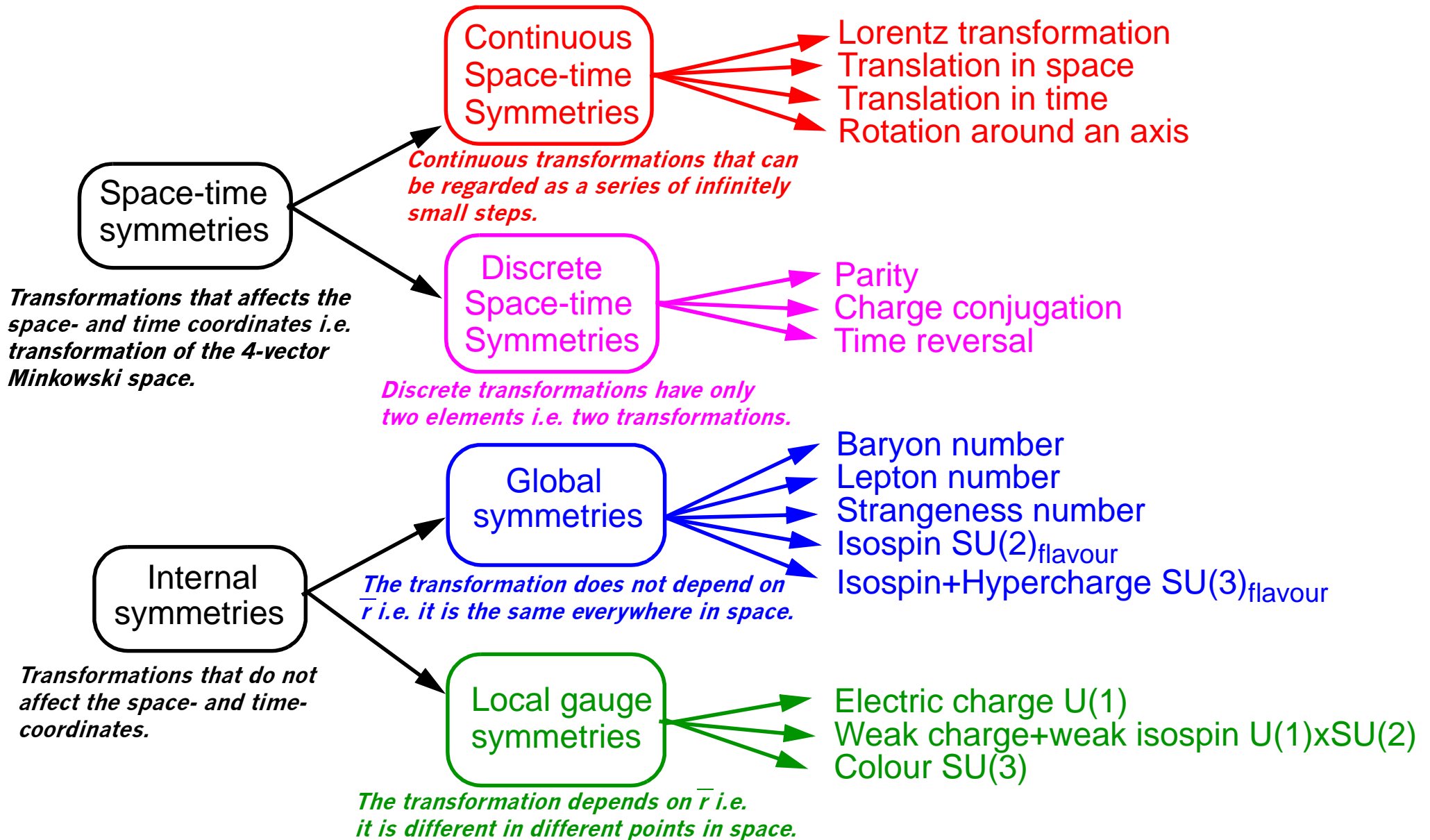

❖ While **parity** is conserved in strong and electromagnetic interactions, it is **violated** in weak processes:

– 1956: Based on the measurements of **Kaon decays**, Lee & Yang propose that parity is violated in weak processes:

Two known decays of the  $K^+$  were:

$$K^+ \rightarrow \pi^0 + \pi^+ \quad \text{and} \quad K^+ \rightarrow \pi^+ + \pi^+ + \pi^-$$

The intrinsic parity of a pion  $P_\pi = -1$ , and for the  $\pi^0\pi^+$  and  $\pi^+\pi^+\pi^-$  states the parities are

$$P_{\pi\pi} = P_\pi^2 (-1)^L = 1 \quad \text{since } L = L_{12} = 0$$

$$P_{\pi\pi\pi} = P_\pi^3 (-1)^L = -1 \quad \text{since } L = L_{12} + L_3 = 0$$

❖ Since the two final states have opposite parities, one of the  $K^+$  decays must **violate parity!**

- 1957: Wu carries out studies of parity violation in  $\beta$ -decay. The  $^{60}\text{Co}$   $\beta$ -decay into  $^{60}\text{Ni}^* + e^- + \bar{\nu}_e$  was studied.
- The  $^{60}\text{Co}$  sample was cooled to 0.01 K to prevent thermal disorder.
- The sample was placed in a magnetic field  $\Rightarrow$  the nuclear spins were aligned along the field direction

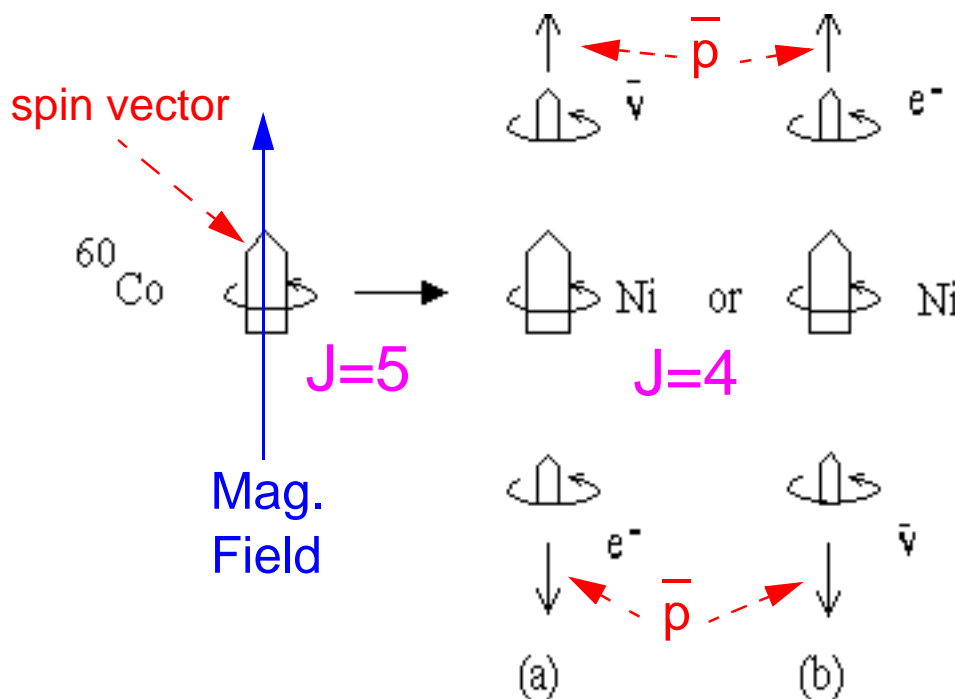

Figure 125: Possible  $\beta$ -decays of  $^{60}\text{Co}$ : case (a) is preferred.

- If parity is conserved, processes (a) and (b) must have equal rates.

❖ *Electrons were emitted predominantly in the direction opposite the  $^{60}\text{Co}$  spin*

→ Another case of both **parity and C-parity violation** was observed in **muon decays**:

$$\mu^- \rightarrow e^- + \bar{\nu}_e + \nu_\mu$$

$$\mu^+ \rightarrow e^+ + \nu_e + \bar{\nu}_\mu$$

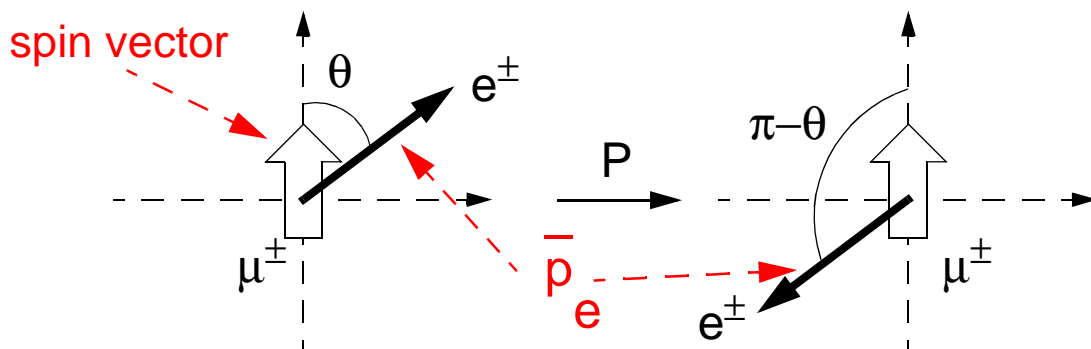

Figure 126: Effect of a parity transformation on the muon decays above

The **angular distribution** of the electrons (positrons) emitted in  $\mu^-$  ( $\mu^+$ ) decay are given by

$$\Gamma_{\mu^\pm}(\cos\theta) = \frac{1}{2}\Gamma_\pm \left( 1 - \frac{\xi_\pm}{3} \cos\theta \right) \tag{136}$$

here  $\xi_\pm$  are constants – “**asymmetry parameters**”, and  $\Gamma_\pm$  are total decay rates  $\Rightarrow$  **inverse lifetimes**

$$\Gamma_\pm = \int_{-1}^1 \Gamma_\pm(\cos\theta) d\cos\theta \equiv \frac{1}{\tau_\pm} \tag{137}$$

→ If the process is invariant under charge conjugation (**C-invariance**)  $\Rightarrow$

$$\Gamma_+ = \Gamma_- \quad \xi_+ = \xi_- \quad (138)$$

(rates and angular distributions are the same for  $e^-$  and  $e^+$ )

→ If the process is **P-invariant**, then angular distributions in forward and backward directions are the same:

$$\Gamma_{\mu^\pm}(\cos\theta) = \Gamma_{\mu^\pm}(-\cos\theta) \quad \xi_+ = \xi_- = 0 \quad (139)$$

→ Experimental results:

$$\Gamma_+ = \Gamma_- \quad \xi_+ = -\xi_- = 1,00 \pm 0,04 \quad (140)$$



**Both C- and P-invariance are violated!**

→ However, the combined operation **CP** is **conserved** since that requires

$$\Gamma_{\mu^+}(\cos\theta) = \Gamma_{\mu^-}(-\cos\theta) \tag{141}$$

$$\Gamma_+ = \Gamma_- \quad \xi_+ = -\xi_- \tag{142}$$

which is in agreement with the experiments.

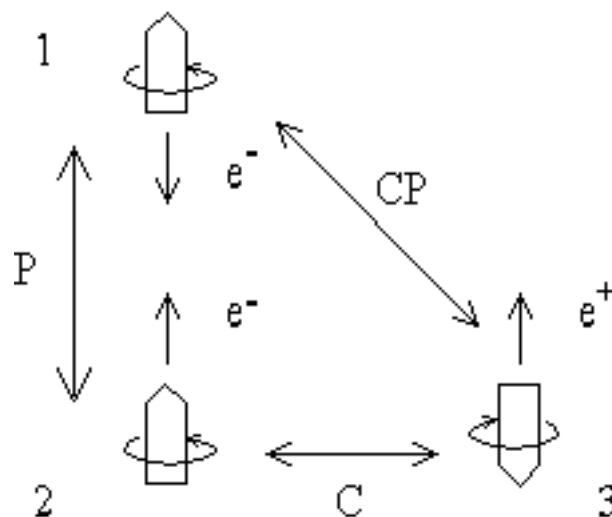

Figure 127: P-, C- and CP-transformation of an electron

❖ The combined transformation **CP** is a weaker requirement than the individual transformations P and C and it is **conserved**.

## Helicity

*helicity* – the spin is quantized along the particle's direction of motion instead of along an arbitrary z-direction

$$\hat{\Lambda} = \frac{\vec{s} \cdot \vec{p}}{|\vec{p}|} \quad (143)$$

$$\hat{\Lambda}\psi = \lambda\psi$$

The eigenvalues of the helicity operator are  $\lambda = -s, -s+1, \dots, +s$ ,  $\Rightarrow$  for spin-1/2 particle it can be either  $-1/2$  or  $1/2$

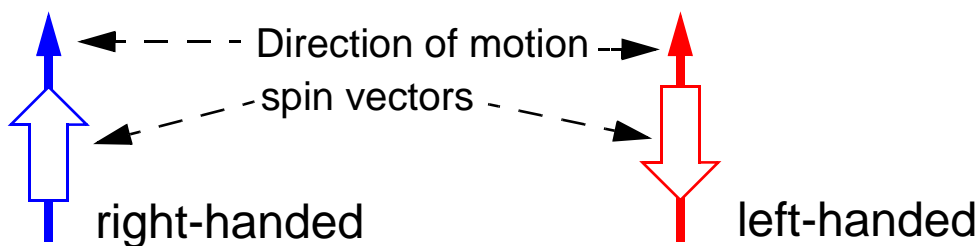

Figure 128: Helicity states of spin-1/2 particle

A particle with  $\lambda = +1/2$  is called **right handed**.

A particle with  $\lambda = -1/2$  is called **left handed**.

A **subscript R or L** is used to denote if a state is right or left handed e.g.  $e^-_R$  and  $\nu_L$



❖ 1958: Goldhaber et al. measured the **helicity of the neutrino** by studying electron capture in europium:

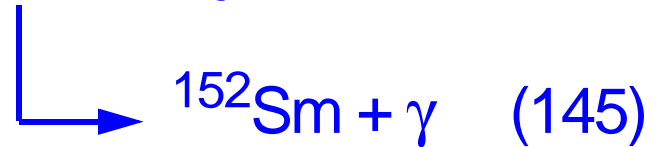

❖ In this reaction the initial state has zero momentum and  ${}^{152}\text{Sm}^*$  and  $\nu_e$  recoil in opposite directions.

❖ Events with the  $\gamma$  emitted in the direction of motion of the  ${}^{152}\text{Sm}^*$  were selected so that the overall observed reaction was:



❖ The spin of the neutrino (+1/2 or -1/2) and the photon (+1 or -1) must add to give the spin of the electron (+1/2 or -1/2).

❖ The helicity (polarization) of the photons was determined by studying their absorption in magnetized iron.

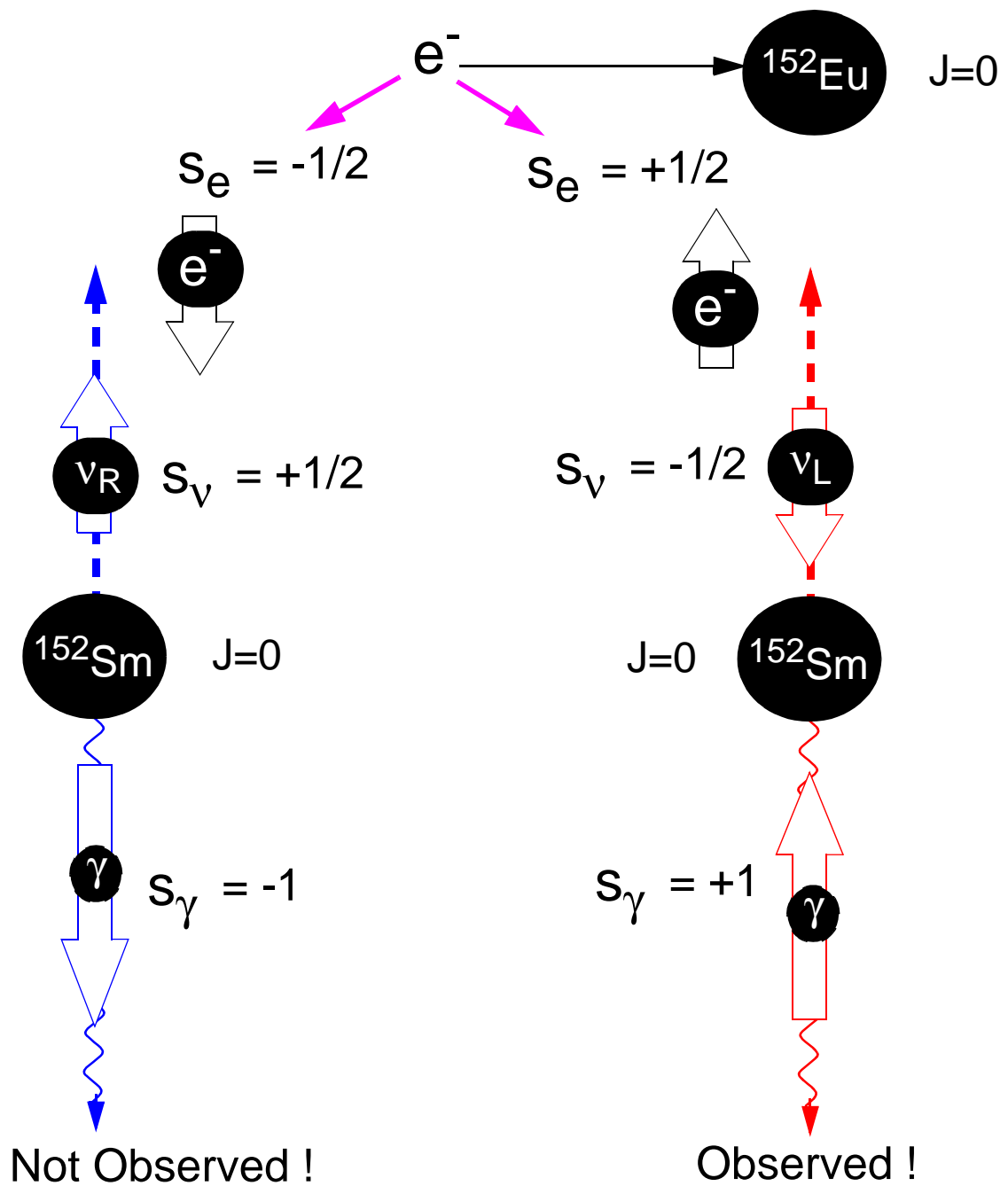

Figure 129: From the helicity of the photons it is possible to determine the helicity of the neutrinos.

❖ From the measured photon helicity it was concluded that **neutrinos must be left-handed.**

## V-A interaction

❖ **V-A interaction** theory was introduced by Fermi as an analytic description of spin dependence of charged current interactions.

❖ It denotes “polar Vector - Axial vector” interaction

– *A Polar vector* is one which direction is reversed by parity transformation e.g. momentum  $\vec{p}$

– *An Axial vector* is one which direction is not changed by parity transformation e.g. spin  $\vec{s}$  or orbital angular momentum  $\vec{L} = \vec{r} \times \vec{p}$

– The weak current has **both vector and axial** components, hence parity is not conserved in weak interactions

→ Main conclusion: if  $v \approx c$ , only **left-handed** fermions  $\nu_L, e_L^-$  etc. are emitted, and right-handed antifermions.

→ *The very existence of preferred states violates both C- and P- invariance*

❖ **Neutrinos** (antineutrinos) are always **relativistic** and hence always **left(right)**-handed

❖ For other fermions, the **preferred states** are **left**-handed. Right-handed states are not completely forbidden but suppressed by the factor

$$\left(1 - \frac{v}{c}\right) \approx \frac{m^2}{2E^2} \tag{147}$$

Consider the two pion decay modes:

$$\pi^+ \rightarrow e^+ + \nu_e \tag{148}$$

$$\pi^+ \rightarrow \mu^+ + \nu_\mu \tag{149}$$

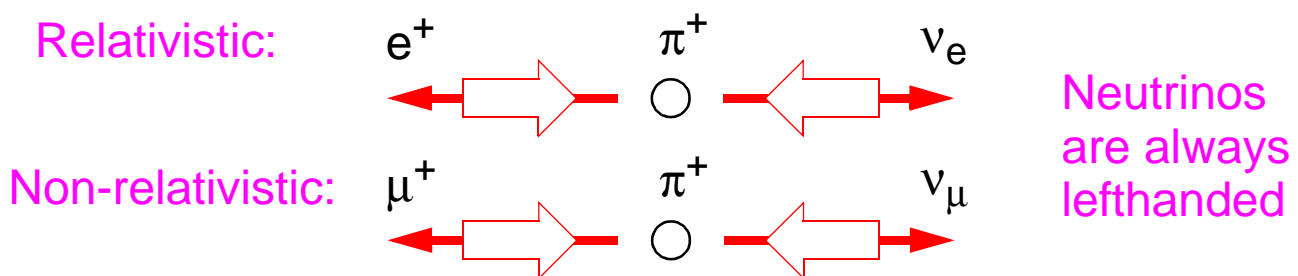

Figure 130: Helicities of leptons emitted in a pion decay

– The  $\pi^+$  has spin-0 and it is at rest  $\Rightarrow$  the spins of the charged lepton and the neutrino must be opposite.

- The neutrinos are always left-handed  $\Rightarrow$  the charged leptons have to be left-handed as well.
- BUT: the  $e^+$  and the  $\mu^+$  should be right-handed since they are anti-fermions.

❖ In these decays the **electron** will be **relativistic** but **not the muon** (due to its large mass).

❖ It follows that the **pion to muon** decay should be **allowed** but the **pion to positron** decay should be **suppressed**.

Left-handed

Should be right-handed since it is relativistic

Can be left-handed since it is non-relativistic

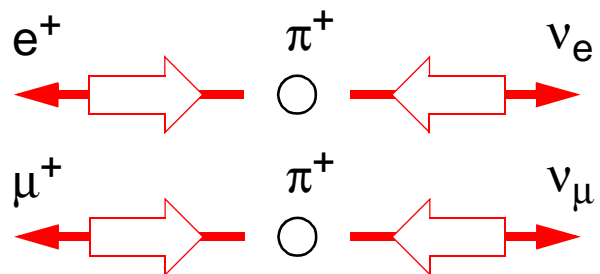

- The suppression factor for positrons is expected to be of the order  $10^{-5}$ .

The measured ratio:

$$\frac{\Gamma(\pi^+ \rightarrow e^+ \nu_e)}{\Gamma(\pi^+ \rightarrow \mu^+ \nu_\mu)} = (1,230 \pm 0,004) \times 10^{-4} \quad (150)$$

❖ **Muons** emitted in pion decays are always **polarized** and this can be used to measure muon decay symmetries by detecting the relativistic electrons in the following decays:

$$\pi^- \rightarrow \mu^- + \bar{\nu}_\mu \tag{151}$$

$$\mu^- \rightarrow e^- + \bar{\nu}_e + \nu_\mu$$

The electrons are emitted in decays when both the  $\nu_\mu$  and the  $\bar{\nu}_e$  are emitted in the direction opposite to the  $e^-$ :

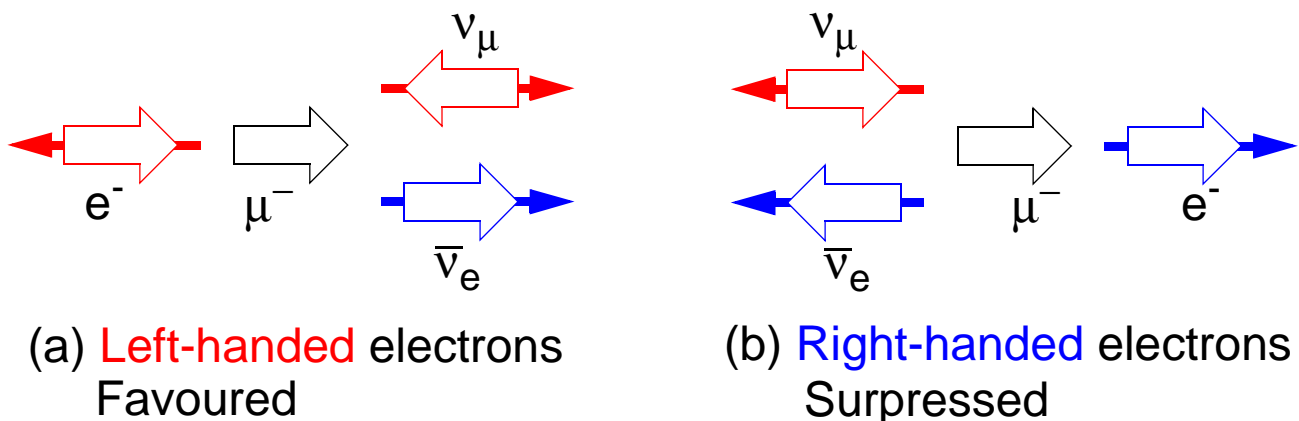

Figure 131: Muon decays with high energy electron emission.

The electron must have a spin parallel to the muon spin  $\Rightarrow$  configuration (a) with left-handed electrons is strongly preferred  $\Rightarrow$  this is observed experimentally as a forward-backward asymmetry.

## Neutral kaons

❖ It is possible to produce the neutral kaons  $K^0 = d\bar{s}$  and  $\bar{K}^0 = s\bar{d}$  in  $\pi p$ -collisions. This is a strong interaction process and strangeness has to be conserved:

$$\pi^- + p \rightarrow K^0 + \Lambda$$

s:      0      0      +1    -1

$$\pi^+ + p \rightarrow \bar{K}^0 + p + K^+$$

s:      0      0      -1    0    +1

❖ The kaons that are produced in this way are pure  $K^0 = d\bar{s}$  and  $\bar{K}^0 = s\bar{d}$  states.

❖ However,  $K^0$  and  $\bar{K}^0$  can be converted into each other since **strangeness is not conserved** in weak interactions:

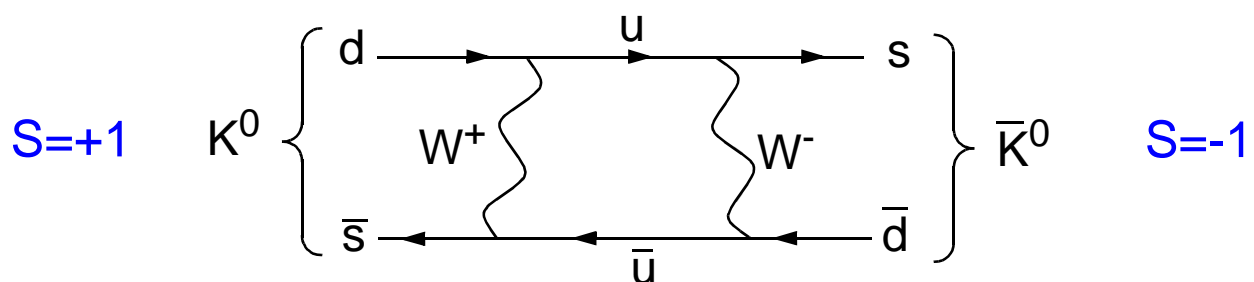

Figure 132: Example of a process converting  $K^0$  to  $\bar{K}^0$ .

❖ The observed physical particles are linear combinations of  $K^0$  and  $\bar{K}^0$ , since there is no conserved quantum number to distinguish them. The phenomenon is called  *$K^0-\bar{K}^0$  mixing*.

❖ We know that neither parity nor charge conjugation are conserved in weak decays. The combined operation **CP** is, however, **almost conserved**.

❖ In this case the CP operators eigenstates can be written as a mixture of  $K^0$  and  $\bar{K}^0$ :

$$K_1^0 = \frac{1}{\sqrt{2}} \{K^0 + \bar{K}^0\} \quad (152)$$

$$K_2^0 = \frac{1}{\sqrt{2}} \{K^0 - \bar{K}^0\} \quad (153)$$

so that

$$\hat{C}PK_1^0 = K_1^0 \text{ and } CPK_2^0 = -K_2^0 \quad (154)$$

i.e. the CP eigenvalues are  $cp=+1$  for  $K_1^0$  and  $cp=-1$  for  $K_2^0$  and the  $K_1^0$  can therefore only decay to  $cp$ -even states while the  $K_2^0$  only to  $cp$ -odd states.



Experimentally observed are two types of neutral kaons:  $K_S^0$  (“S” for “short”, lifetime  $\tau = 0,9 \times 10^{-10} s$ ) and  $K_L^0$  (“long”,  $\tau = 500 \times 10^{-10} s$ ).

❖ Can the  $K_S^0$  be identified with the  $K_1^0$  CP-eigenstate, and the  $K_L^0$  with the  $K_2^0$  ?

→ If CP-invariance holds for neutral kaons,  $K_S^0$  should decay only into states with  $cp=1$  such as  $2\pi$ -states, and  $K_L^0$  into states with  $cp=-1$  such as  $3\pi$ -states:

$$K_S^0 \rightarrow \pi^+ \pi^-, \quad K_S^0 \rightarrow \pi^0 \pi^0 \quad (155)$$

- The parity of a two-pion state is  $P = P_\pi^2 (-1)^L = 1$
- The C-parity of a  $\pi^0 \pi^0$  state is  $C = (C_{\pi^0})^2 = 1$ , and of a  $\pi^+ \pi^-$  state:  $C = (-1)^L = 1$
- i.e.  $cp=1$  for the  $\pi^+ \pi^-$  and  $\pi^0 \pi^0$  states
- i.e. the assumption that  $K_S^0 = K_1^0$  seem to be correct.

$$K_L^0 \rightarrow \pi^+ \pi^- \pi^0, \quad K_L^0 \rightarrow \pi^0 \pi^0 \pi^0 \quad (156)$$

- The parity of the 3- $\pi$  states are -1
- The C-parity of  $\pi^0 \pi^0 \pi^0$  is  $C = (C_{\pi^0})^3 = 1$
- The C-parity of  $\pi^+ \pi^- \pi^0$  is  $C = C_{\pi^0} (-1)^{L_{\pi\pi}} = 1$
- i.e. the 3- $\pi$  final states above have  $CP = -1$
- i.e. the assumption that  $K_L^0 = K_2^0$  seem to be correct.



### Summary:

The neutral Kaon eigenstates in **strong interactions** are:

$$K^0 = d\bar{s}$$

$$\bar{K}^0 = s\bar{d}$$

The neutral Kaon eigenstates in **weak interactions** (if CP is conserved) are:

$$K_s^0 = K_1^0 = \frac{1}{\sqrt{2}} \{K^0 + \bar{K}^0\}$$

$$K_L^0 = K_2^0 = \frac{1}{\sqrt{2}} \{K^0 - \bar{K}^0\}$$

# CP-violation

The *CP-violating* decay

$$K_L^0 \rightarrow \pi^+ \pi^- \tag{157}$$

was first observed in 1964, with a branching ratio of  $B \approx 10^{-3}$ .

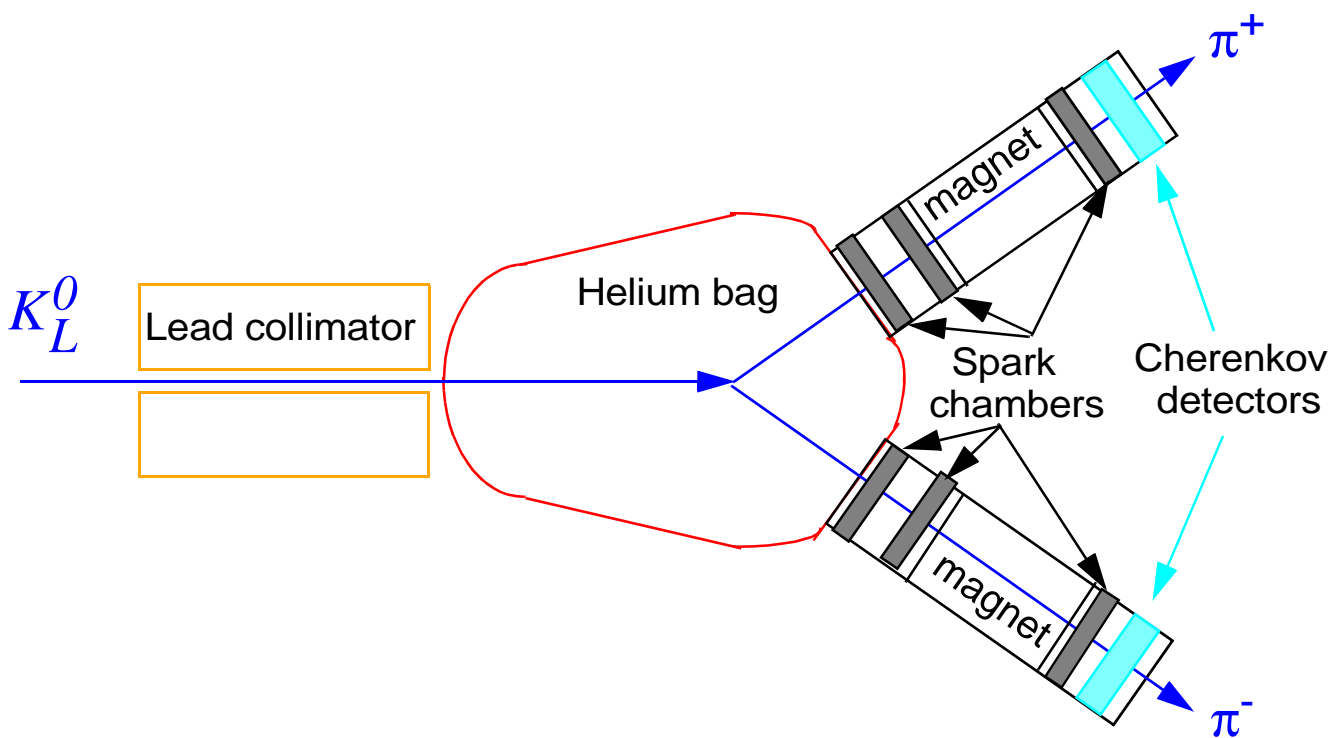

Figure 133: Sketch of the experiment that discovered CP-violation in weak decays.

❖ In general, the physical states  $K_S^0$  and  $K_L^0$  don't have to correspond to pure CP-eigenstates  $K_1^0$  and  $K_2^0$ . Instead

$$K_S^0 = \frac{1}{\sqrt{1 + |\varepsilon|^2}} \{K_1^0 + \varepsilon K_2^0\}$$

$$K_L^0 = \frac{1}{\sqrt{1 + |\varepsilon|^2}} \{\varepsilon K_1^0 + K_2^0\}$$

where  $\varepsilon$  is a small complex parameter:  $|\varepsilon| = 2 \times 10^{-3}$

❖  $K_S^0$  contains **mostly**  $K_1^0$  but has also a small  $K_2^0$  component while  $K_L^0$  consists mostly of  $K_2^0$  with a small component of  $K_1^0$ .

→ Mixing occur also for neutral **B-mesons** ( $B^0 = \bar{d}b$ ,  $\bar{B}^0 = bd$ ,  $B_S^0 = \bar{s}b$  and  $\bar{B}_S^0 = bs$ ) and for neutral D-mesons ( $D^0 = c\bar{u}$  and  $\bar{D}^0 = uc$ ).

→ There can be **different mechanisms** for CP-violation, especially in the  $B^0$ - $\bar{B}^0$  systems. Several dedicated experiments have been built to study this system.

## Summary

### • Parity and charge conjugation

- a) Parity is violated in weak processes.
- b) Parity violation was first observed in  $^{60}\text{Co}$ -decays.
- c) Muon decays can be used to show that both parity and charged conjugation is violated while the combined CP operation is conserved.

### • Helicity

- d) Helicity is the spin quantized along the direction of motion.
- e) Neutrinos are left-handed and antineutrinos right-handed.
- f) This was first observed in reactions between electrons and  $^{152}\text{Eu}$  atoms.

---

- **V-A interactions**

g) While neutrinos are always left-handed other fermions are exclusively left-handed only when they are relativistic.

- **Neutral kaons**

h) The neutral kaons that are observed experimentally ( $K^0_S$  and  $K^0_L$ ) are due to  $K^0$ - $\bar{K}^0$  mixing

i) CP-violating decays of neutral kaons have been observed with a small branching ratios.